

I **INSTALLATION INSTRUCTIONS**

and PERIODIC MAINTENANCE

G-Series

Rotators

Manual Number 6073002-R3

cascade[®]
corporation

Cascade is a Registered Trademark of Cascade Corporation

C ONTENTS

Introduction	i
Special Definitions	1
Recommended Hydraulic Supply	1
Truck Requirements	2
Installation	3
Periodic Maintenance	12

I NTRODUCTION

This manual provides installation instructions and periodic maintenance requirements for Cascade G-Series Rotators.

In any communication about the Rotator refer to the product I.D. number stamped on the nameplate. If the nameplate is missing, the numbers can be found stamped on the left frontside of the faceplate between the fork bars.

IMPORTANT: All hoses, tubes and fittings on G-Series Rotators are JIC.

NOTE: Specifications are shown in both U.S. and (Metric) units.

Nameplate
(frontside of
faceplate)

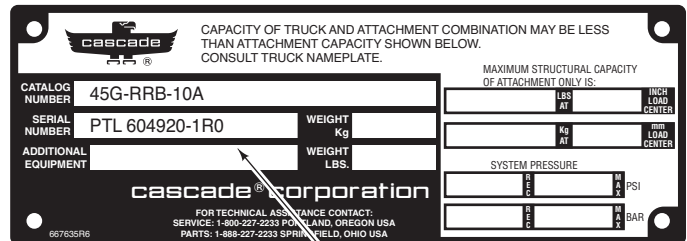
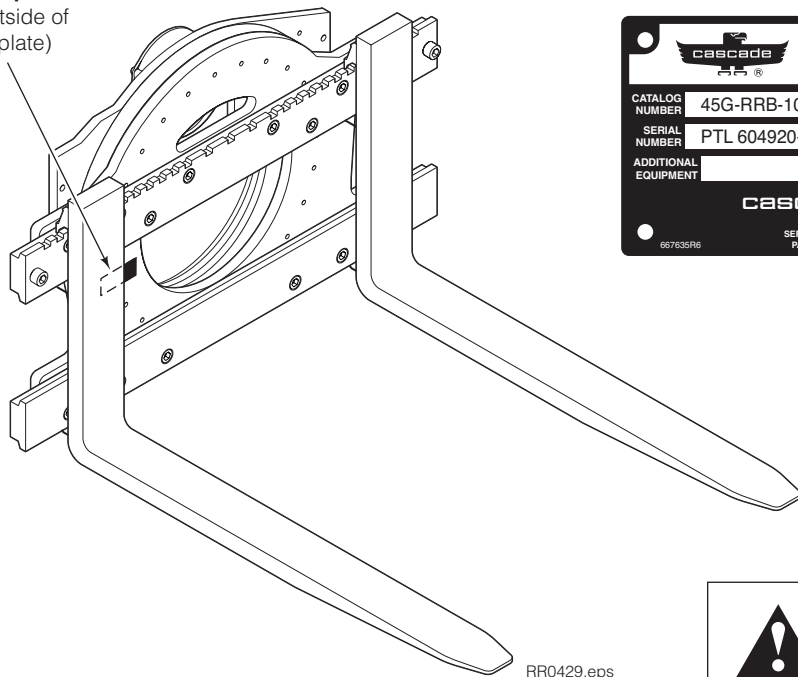

WARNING - Fork size affects Rotator capacity. Consult Cascade page 10. Verify capacity for truck nameplate.

SPECIAL DEFINITIONS

The statements shown below appear throughout this Manual where special emphasis is required. Read all WARNINGS and CAUTIONS before proceeding with any work. Statements labeled IMPORTANT and NOTE are special information that is useful when servicing the attachment.



WARNING - A statement preceded by a WARNING is information that should be acted upon to prevent **bodily injury**. A WARNING is always inside a ruled box.

CAUTION – A statement preceded by CAUTION is information that should be acted upon to prevent machine damage.

IMPORTANT – A statement preceded by IMPORTANT is information that possesses special significance.

NOTE – A statement preceded by NOTE is information that is handy to know and may make the job easier.

RECOMMENDED HYDRAULIC SUPPLY

G-Series Rotators provide the best performance with one of the hydraulic supply arrangements shown. Refer to *Cascade Hose and Cable Reel Selection Guide*, Part No. 212199, to select the correct hose reel for the mast and truck. The hose and fitting requirements are:

- **ROTATE Function:**

- **30G-40G** –

- No. 6 with 9/32 in. (9 mm) minimum I.D.

- **45G-100G** –

- No. 8 with 13/32 in. (10 mm) minimum I.D.

A

RH or LH Single Internal Hose Reeling Group.

OR

B

RH or LH THINLINE™ 2-Port Hose Reel Group.

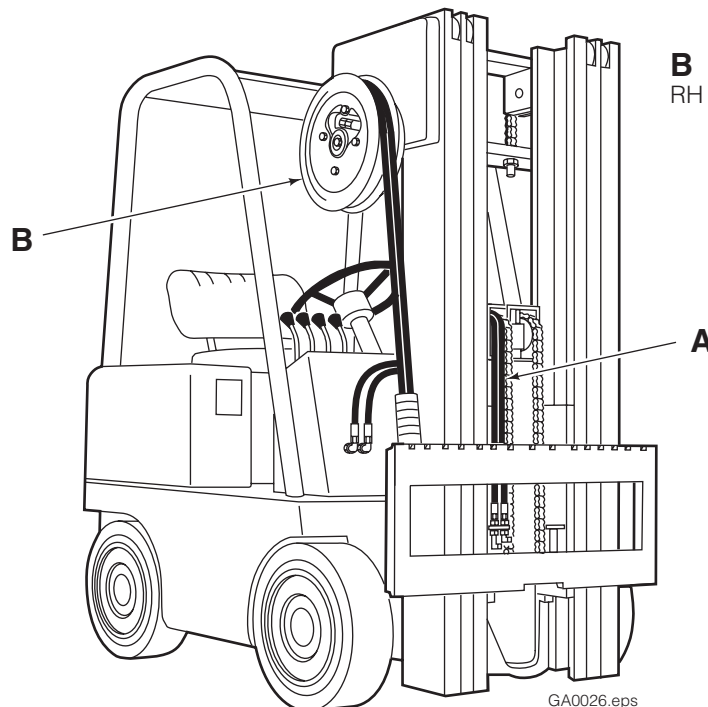

GA0026.eps

T RUCK REQUIREMENTS



WARNING: Rated capacity of the truck/attachment/fork combination is a responsibility of the original truck manufacturer and may be less than that shown on the attachment nameplate. Consult the truck nameplate.

Truck Relief Setting

2300 psi (160 bar) Maximum

Truck Flow Volume ^①

	Min. ^②	Recommended	Max. ^③
30G, 40G	5 GPM (20 L/min)	7.5 GPM (28 L/min)	10 GPM (38 L/min)
45G, 55G, 65G, 80G, 100G	5 GPM (20 L/min)	10 GPM (38 L/min)	15 GPM (56 L/min)

① Cascade Rotators are compatible with SAE 10W petroleum base hydraulic fluid meeting Mil. Spec. MIL-0-5606 or MIL-0-2104B. Use of synthetic or aqueous base hydraulic fluid is not recommended. If fire resistant hydraulic fluid is required, special seals must be used. Contact Cascade.

② Flow less than recommended will result in a rotate speed less than 2 RPM.

③ Flow greater than maximum can result in excessive heating, reduced system performance and short hydraulic system life.

Hoses and Fittings

30G–40G: No. 6 with 9/32 in. (7 mm) minimum ID

45G–100G: No. 8 with 13/32 in. (10 mm) minimum ID.

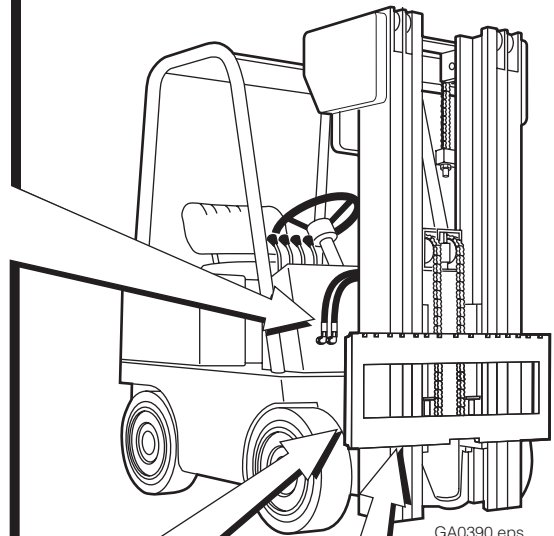

Carriage Mount Dimension (A) ANSI (ISO)



	Minimum	Maximum
Class II	14.94 in. (380.0 mm)	15.00 in. (381.0 mm)
Class III	18.68 in. (474.5 mm)	18.74 in. (476.0 mm)
Class IV	23.44 in. (595.5 mm)	23.50 in. (597.0 mm)

Carriage – Clean and inspect carriage bars for damage and smoothness. Repair any protruding welds or damaged notches.

Auxiliary Valve Functions

Check for compliance with ANSI(ISO) standards.

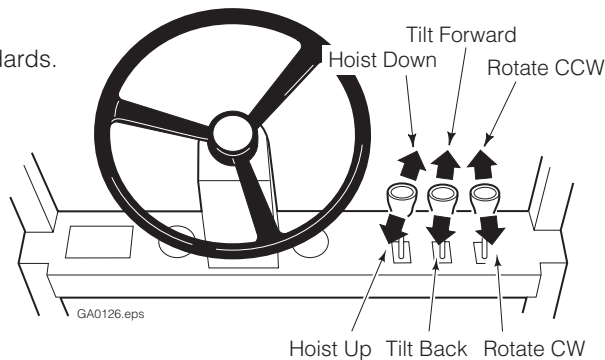

INSTALLATION

Follow the steps shown to install the Rotator on the truck. Read and understand all **WARNING** statements. If you don't understand a procedure, ask your supervisor or call the nearest Cascade Service Department for assistance.

1 Attach overhead hoist, remove bolt-on lower hooks

- A** Remove banding, set Rotator upright on pallet.
- B** Remove bolt-on lower mounting hooks (if equipped).

WARNING: Check weight on nameplate of Rotator and make sure overhead hoist and chains or slings are rated appropriately.

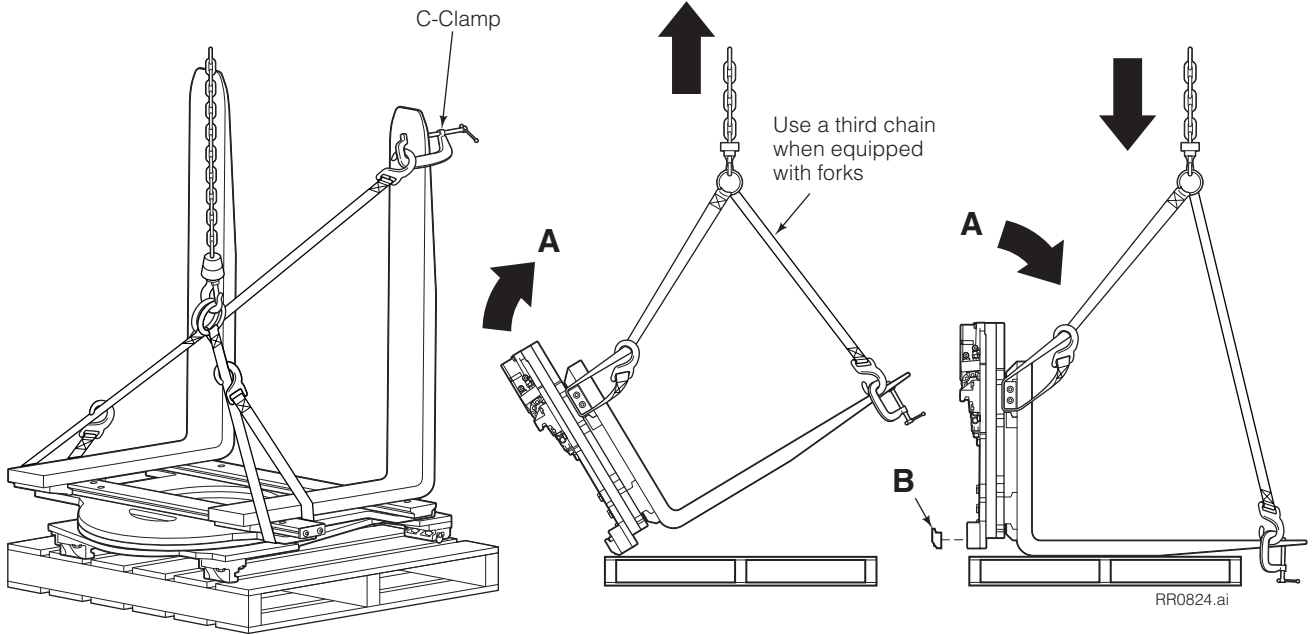

2 Unlock Quick-Change lower mounting hooks (if equipped)

- A** Move hooks into unlocked position (pin in lower hole).

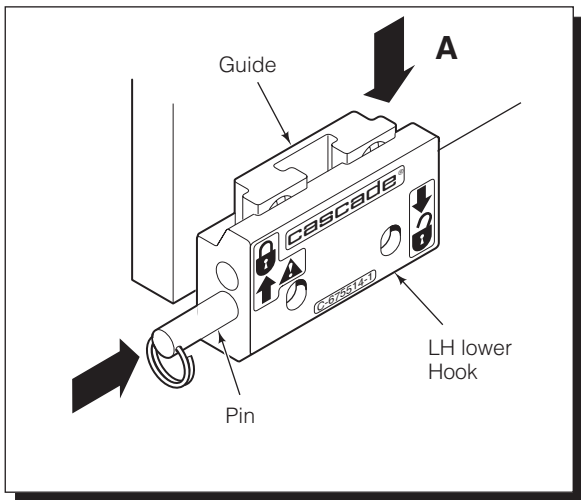

NOTE: Guides can be reversed to change hook to carriage clearance (See Step 7).

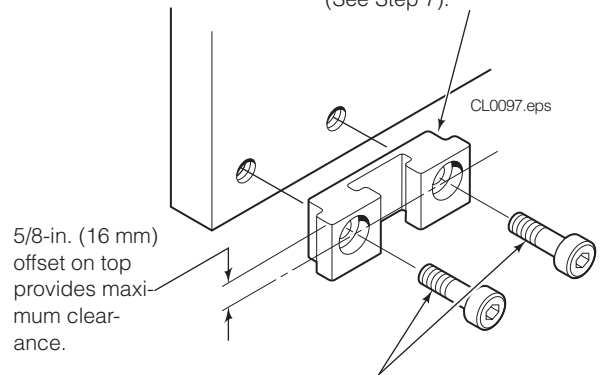

Apply Loctite 242 (blue) and tighten cap screws:
CL II/III – 120 ft.-lbs. (165 Nm)

3 Prepare Hoses

- A** Position truck carriage behind Rotator.
- B** Determine hose lengths required.
- C** Cut hoses to length and install end fittings.

IMPORTANT: Flush hoses (Step 4) before operating Rotator.

CAUTION: Hoses should be 2300 psi (160 bar) working pressure rated for 30G-100G attachment functions.

INSTALLATION USING RH 2-PORT *THINLINE™* HOSE REEL:

30G-40G

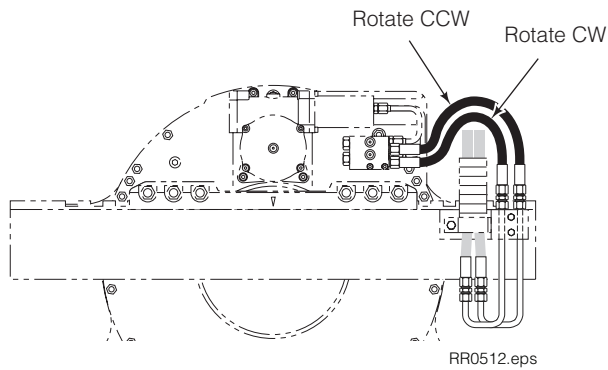

INSTALLATION USING INTERNAL HOSE REEVIING:

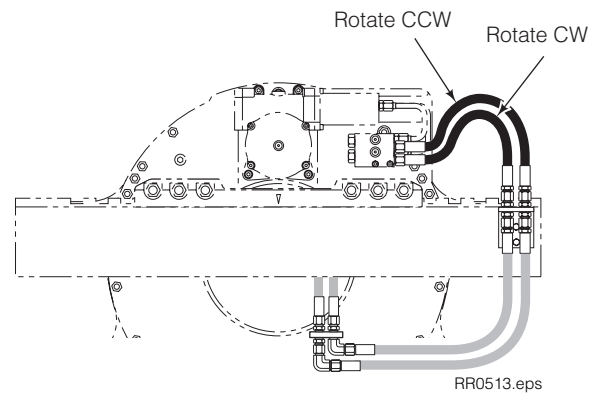

45G-100G

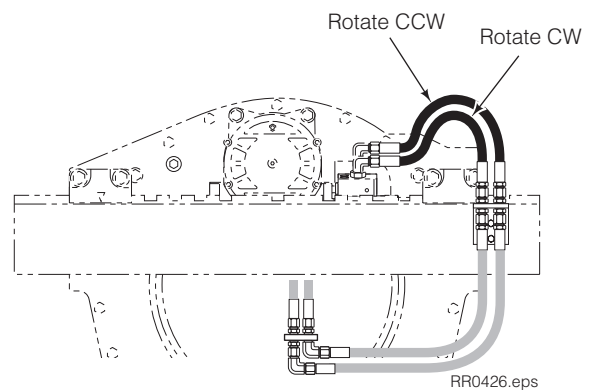
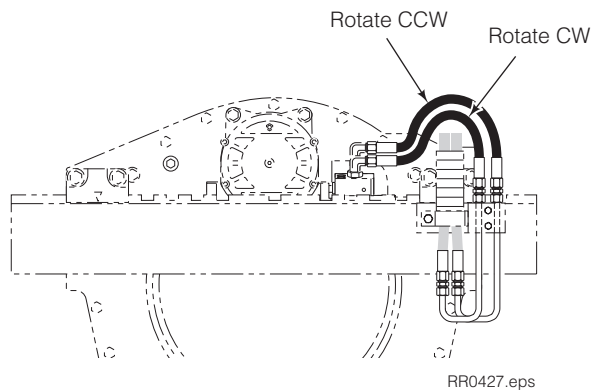

G-Dual Drive

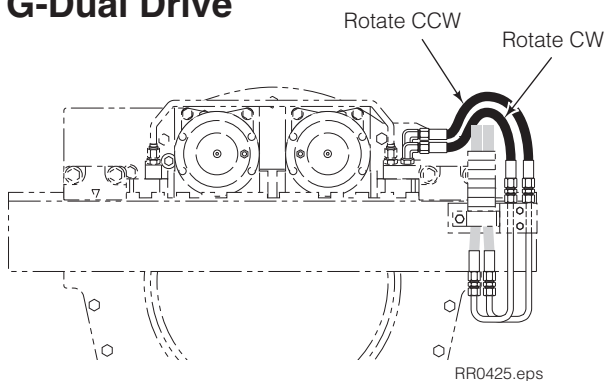

4 Flush hydraulic supply hoses

- A Install hoses as shown below.
- B Operate auxiliary valves for 30 sec.
- C Remove union fittings.

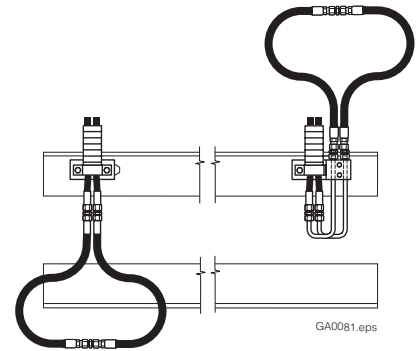

GA0081.eps

5 Remove gearbox end cover level hole Check lubricant level

If necessary, fill gearbox with Cascade Gear Lube 656300 or equivalent SAE 90 wt. gear lube (AGMA 'mild' 6EP Gear Oil).

30G-40G

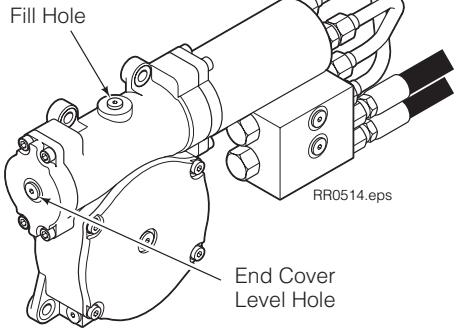

RR0514.eps

45G-100G

End Cover Hole (level and fill hole)

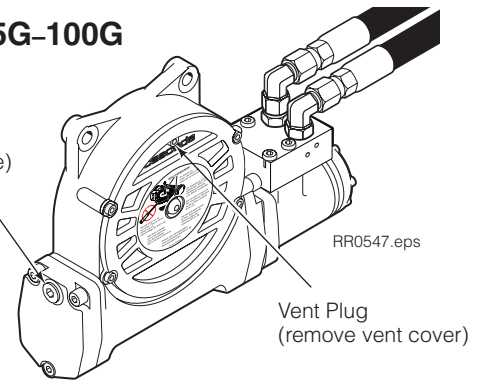

RR0547.eps

Vent Plug (remove vent cover)

6 Mount Rotator on truck carriage

- A Center truck behind Rotator.
- B Tilt forward and raise carriage into position.
- C Engage top mounting hooks with carriage.
 - 30G-40G** – Make sure the centering tab engages the center notch on top carriage bar.
 - 45G-100G** – Make sure locator tab in left hook engages closest notch on top carriage bar.
- D Lift Rotator 2 in. (5 cm) off pallet.

30G-40G

Centering Tab

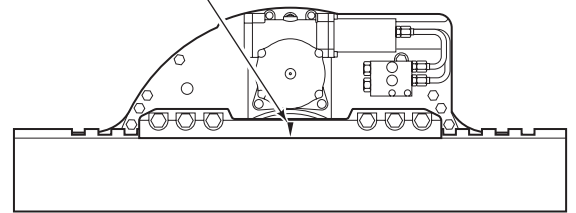

RR0515.eps

45G-100G

(Class III mounting shown)

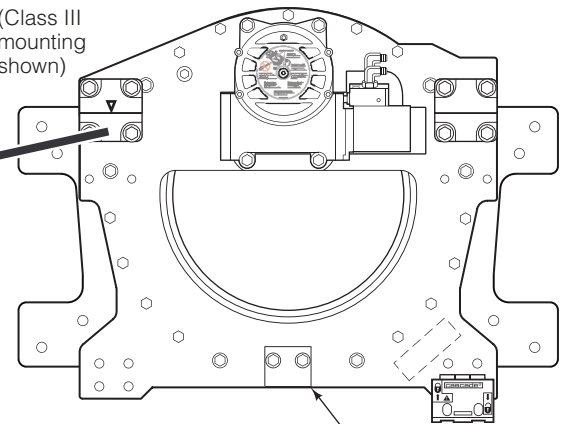

RR0434.eps

- ITA Class II – 0.60–0.66 in. (15–17 mm)
- ITA Class III – 0.72–0.78 in. (18–20 mm)
- ITA Class IV – 0.72–0.78 in. (18–20 mm)

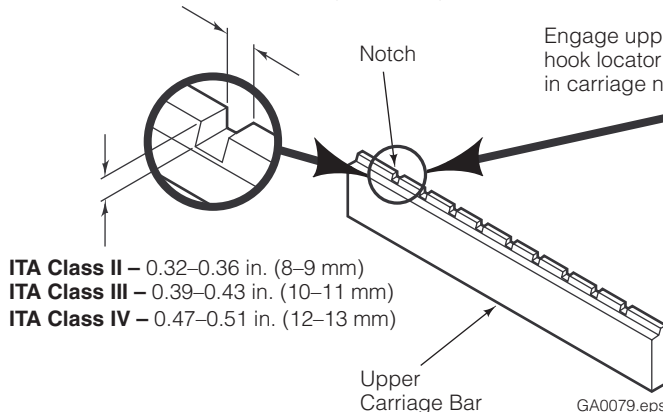

GA0079.eps

- ITA Class II – 0.32–0.36 in. (8–9 mm)
- ITA Class III – 0.39–0.43 in. (10–11 mm)
- ITA Class IV – 0.47–0.51 in. (12–13 mm)

Upper Carriage Bar

Center Spacer

7 Install and engage lower hooks

BOLT-ON TYPE

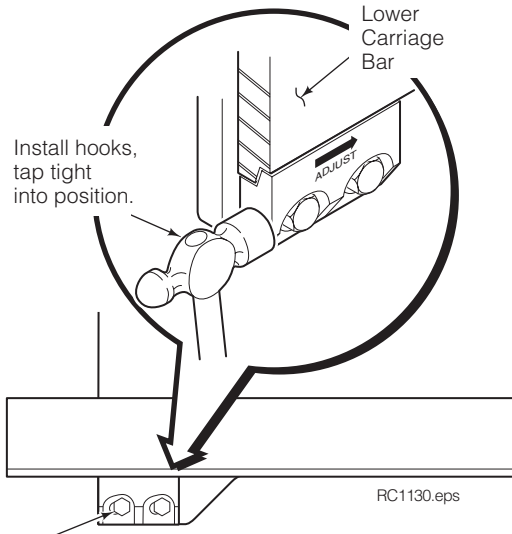

Apply Loctite 242 (blue) and tighten Capscrews:
CL II/III – 120 ft.-lbs. (165 Nm)
CL IV – 195 ft.-lbs. (265 Nm)

QUICK-CHANGE TYPE

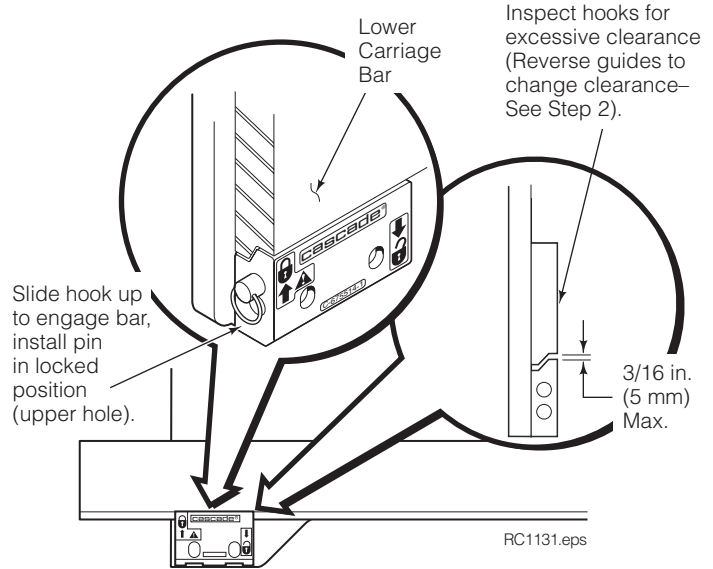

INSTALLATION

8 Connect hoses to hose terminal fittings as shown in Step 3

INSTALLATION USING RH 2-PORT THINLINE™ HOSE REEL:

30G-40G

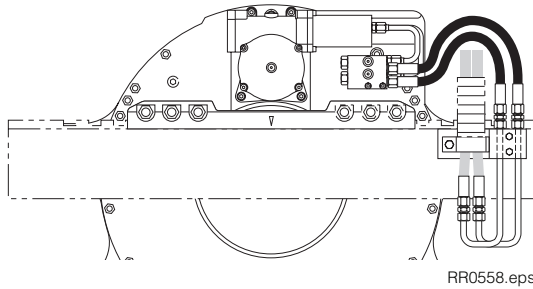

INSTALLATION USING INTERNAL HOSE REEVING:

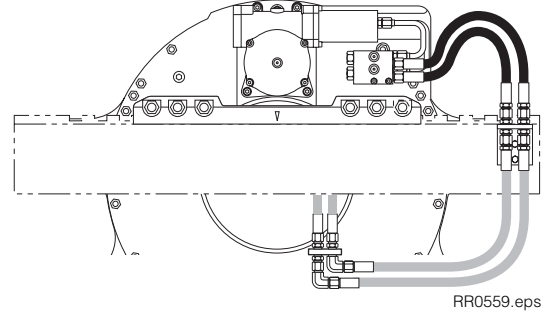

45G-100G

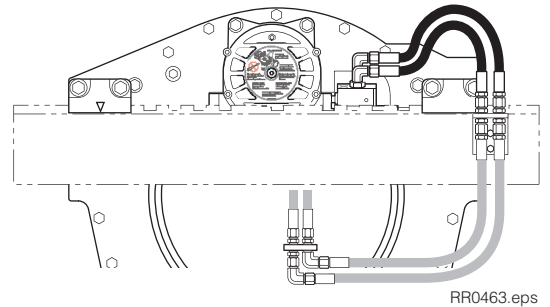
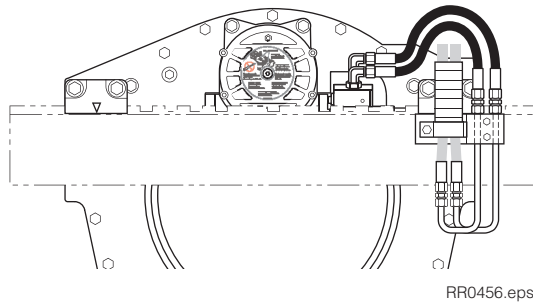

9 Install stop block kit

- Locate a stop block on the outside of each upper hook. Preheat stop block and carriage bar weld area to 325° F (180° C).
- Use AWS E7018 low hydrogen rod and weld a .25 in. (6 mm) fillet full length on three sides of each stop block.

45G-100G

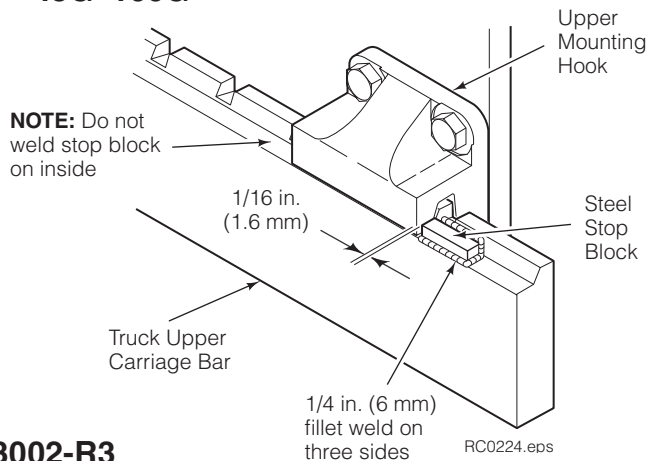

30G-40G

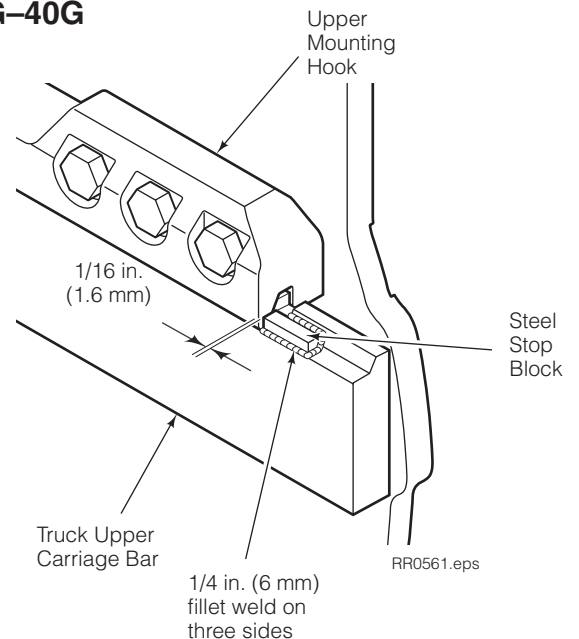

10

Cycle Rotation Function



WARNING: Make sure all personnel are clear of the Rotator during testing.

- With no load, cycle rotation function several times.
- Check functions for operation in accordance with ANSI (ISO) standards.
- Pick up a maximum load and rotate. Check for smoothness and normal rotation.
- Check for leaks at hoses, fittings and rotator drive.

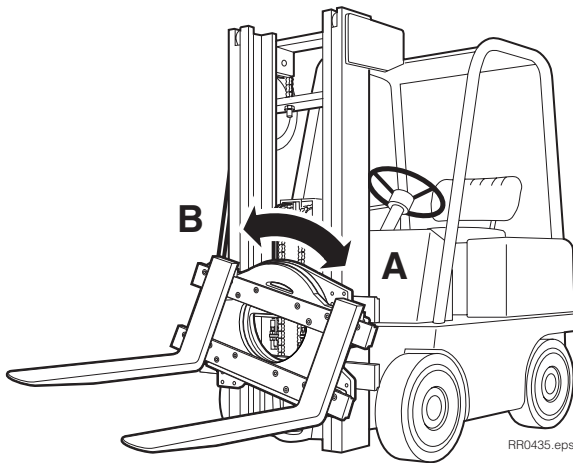

WARNING: Truck control handle and attachment function activation shown here conforms to ASME/ANSI B56.1 recommended practices. Failure to follow these practices may lead to serious bodily injury or property damage. End user, dealer and OEMs should review any deviation from the practices for safe operation.

Auxiliary Valve Functions

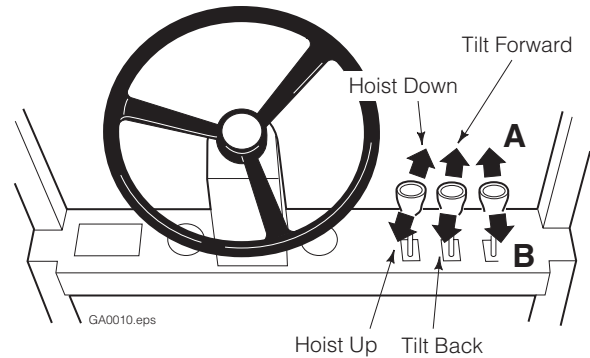

ROTATE
(Driver's view)

A Counterclockwise (CCW)

B Clockwise (CW)

11 Fork Welding Preparation (forks without middle hook installed)

- A** Clean all surfaces to be welded. Remove paint, oil, grease and other contaminants.
- B** Position the middle hook using the dimensions shown. Mark the hook position on the fork.
- C** Tack the hook in four places with .25 in. (6 mm) long welds. Recheck dimensions.

Rotator Model	Hook Spacing Dimension 'A'
30G, 40G, 45G, 55G	3.05 +.06 -0 in. (77.5 +1.5 -0 mm)
65G	3.60 +.06 -0 in. (91.5 +1.5 -0 mm)
80G	4.70 +.06 -0 in. (119.5 +1.5 -0 mm)
100G	5.85 +.06 -0 in. (148.6 +1.5 -0 mm)



WARNING: Each fork must have three hooks. Cascade forks for rotators are equipped with a middle hook. If the rotator is supplied without forks, middle hooks are provided. They must be welded using the following procedures.

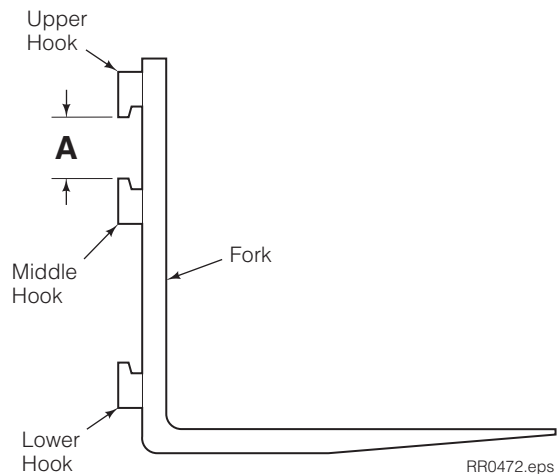

12 Fork Middle Hook Welding

- A** Preheat weld area (full fork width and 6 in. above and below hook) to 400° F (204° C) minimum, 500° F (260° C) maximum before welding. Maximum interpass temperature should not exceed 650° F (343° C).
- B** Weld middle hook to fork. Run the weld around the hook using the weld dimensions shown in the table below. Overlap the start position to eliminate arc craters. Use one of the following weld methods:

WELD METHOD A – Attach ground clamp to the fork upright. Weld using FCAW (Flux Core Arc Welding). AWS E70T-1 electrode, .06 in. (1.5 mm) diameter with 100% CO₂ or 75% Ar/ 25% CO₂ @ 30-45 CFH. Apply fillet and groove welds using stringer bead technique. Minimum weld pass width .25 in. (6.3 mm), maximum weld pass thickness .50 in. (12.5 mm). DCRP welding current, 230-300 amps, 29-31 volts. Travel speed 8-12 IPM. Completely remove slag between passes. Slow cool, by covering with insulating blanket, to 150° F (65° C).

WELD METHOD B – Attach ground clamp to the fork upright. Weld using SMAW (Shielded Metal Arc Welding). AWS E-7018 electrode, .15 in. (4 mm) diameter. DCRP constant current power source, 145-225 amps. Use only properly stored electrodes from controlled storage or hermetically sealed containers. Electrodes exposed to the atmosphere for more than 4 hours must be redried at 500° F (260° C) for 2 hours. Weld using stringer bead technique. Minimum weld pass width .25 in. (6.3 mm), maximum weld pass thickness .50 in. (12.5 mm). Completely remove slag between passes. Slow cool, by covering with insulating blanket, to 150° F (65° C).

- C** Inspect welds. No undercut, overlap, cracks of any kind (including crater crackers) or porosity.
- D** Clean weld area and repaint.

Rotator Model	No-Weld Dimension 'B'	Weld Dimension 'C'	Weld Dimension 'D'
30G, 40G, 45G, 55G	.56 in. (14 mm)	.39 in. (10 mm)	.47 in. (12 mm)
65G	.64 in. (16 mm)	.39 in. (10 mm)	.47 in. (12 mm)
80G	.47 in. (12 mm)	.39 in. (10 mm)	.47 in. (12 mm)
100G	.64 in. (16 mm)	.38 in. (10 mm)	.50 in. (12 mm)



WARNING: Applications that hold a load inverted with a 50% or more capacity, must use Cascade rotator forks.

Applications that dump a load when rotator is rotated at 45° from vertical, can use pallet forks with the installed middle hook.

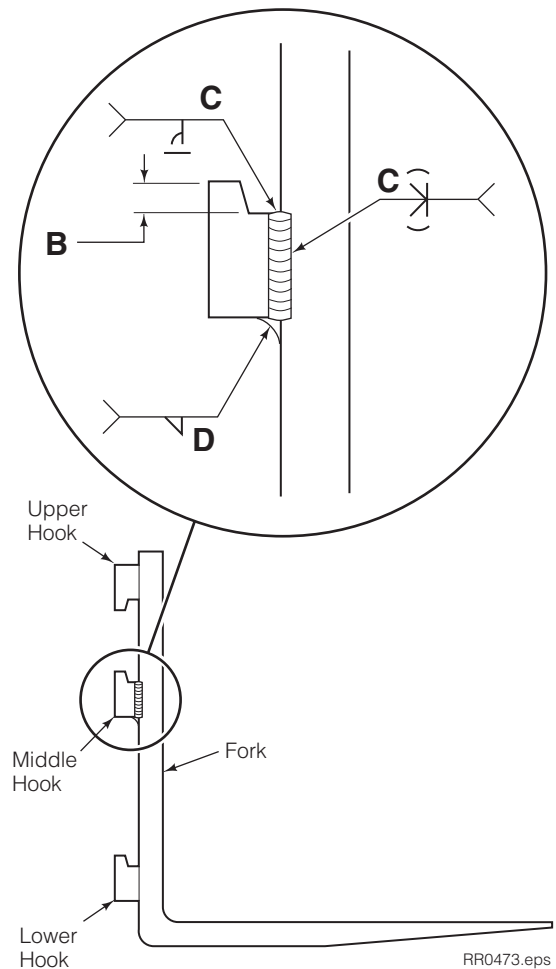

RR0473.eps

13 Install forks

Make sure forks are rated for the loads being handled. Fork size chosen may reduce Rotator rating (see next page).



WARNING: Forks must have **three hooks**. Cascade forks for rotators are already equipped with a middle hook. If the rotator is supplied without forks, middle hooks are provided. See Step 11 for middle hook installation procedure.

- A** Rotate the carriage to the horizontal position. Remove the fork keepers from the upper fork carriage bar.
- B** Release the spring locks on top of the forks.
- C** Slide the forks into position on the fork carriage bars.

NOTE: If the fork middle hook fit up is too tight, sand or grind the tip.
- D** Lock each fork in place by pushing the spring lock lever down or twisting the button down. Shake forks to make sure the pin is fully engaged in a fork bar notch.
- E** Reinstall the keepers. Tighten the capscrews to a torque of:

Capscrew Type:

30G-100G - 185-200 ft.-lbs. (250-270 Nm)

Bar Type:

45G-65G - 60-65 ft.-lbs. (80-90 Nm)

Apply Loctite 242 (blue) to Bar Type capscrews. Threaded holes must be clean and dry before reassembly.

- F** Reverse the above procedures for removal.



WARNING: When installing or removing forks, rotate carriage to **horizontal position**. Use pallets or blocks to raise forks to installation height. Keep feet clear of forks when installing. **Fork keepers must be in place at all times during Rotator operation.**

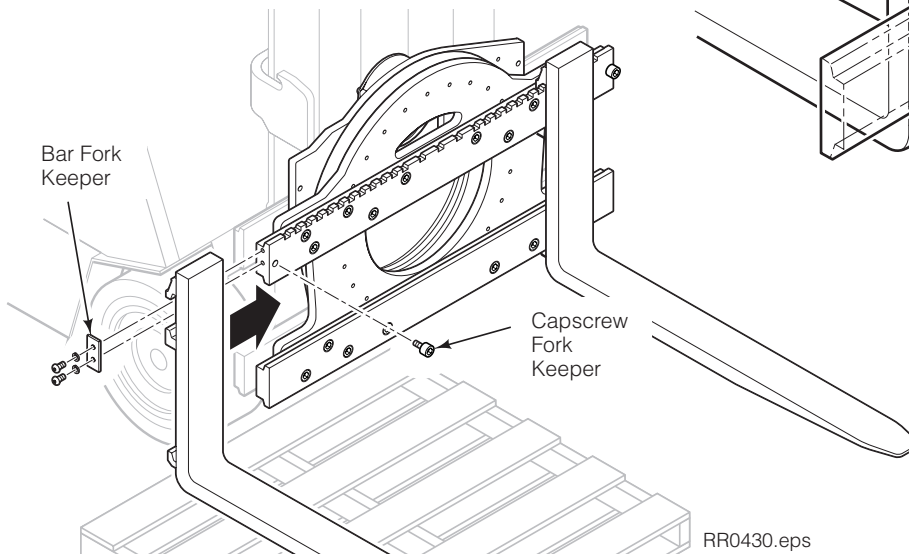
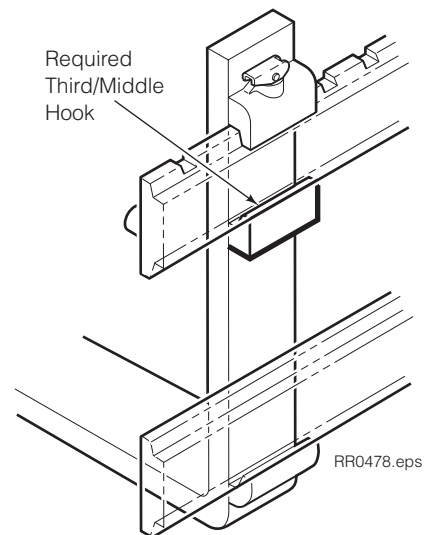
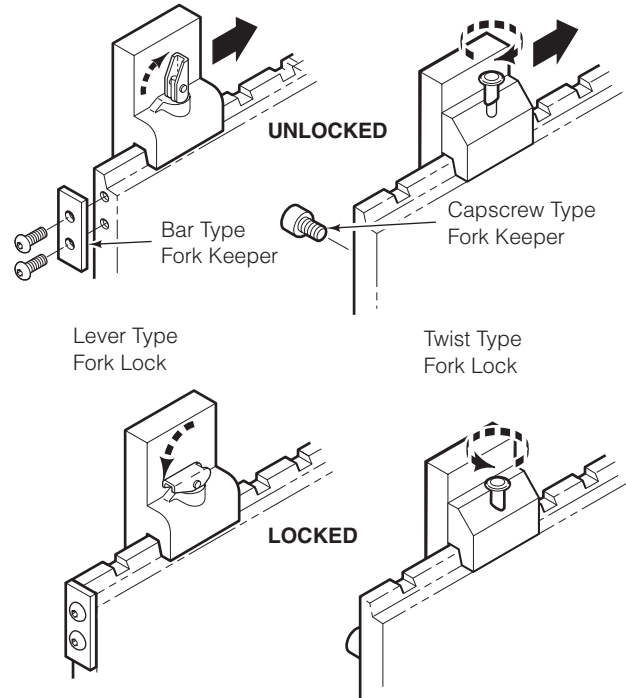

CAUTION: Rotator and fork capacity are dependant on fork size.
Shaded area indicates maximum rating fork size.

ROTATOR & FORK CAPACITY at 24 in. Load Center (600 mm)									
Model	Fork Class	Fork Size (W x T)							
		4 x 1.25 in.	100 x 35 mm	4 x 1.50 in.	100 x 40 mm	5 x 1.50 in.	122 x 40 mm	5 x 1.75 in.	122 x 45 mm
30G	II	3,000 lbs.	1,361 kg	3,000 lbs.	1,361 kg	3,000 lbs.	1,361 kg	3,000 lbs.	1,361 kg
40G	II	3,145 lbs.	1,427 kg	4,000 lbs.	1,815 kg	4,000 lbs.	1,815 kg	4,000 lbs.	1,815 kg
45G	II	3,145 lbs.	1,427 kg	4,500 lbs.	2,042 kg	4,500 lbs.	2,042 kg	4,500 lbs.	2,042 kg
55G	II	3,145 lbs.	1,427 kg	4,675 lbs.	2,121 kg	5,100 lbs.	2,314 kg	5,500 lbs.	2,495kg
65G	III	–	–	–	–	5,100 lbs.	2,314 kg	6,500 lbs.	2,949 kg
80G	III	–	–	–	–	–	–	6,460 lbs.	2,930 kg
100G	III	–	–	–	–	–	–	6,460 lbs.	2,930 kg

Model	Fork Class	Fork Size (W x T)							
		5 x 2.00 in.	122 x 50 mm	6 x 2 in.	150 x 50 mm	6 x 2.5 in.	150 x 65 mm	7 x 2 in.	180 x 50 mm
65G	III	6,500 lbs.	2,949 kg	–	–	–	–	–	–
80G	III	8,000 lbs.	3,629 kg	8,000 lbs.	3,629 kg	8,000 lbs.	3,629 kg	8,000 lbs.	3,629 kg
100G	III	8075 lbs.	3,663 kg	10,000 lbs.	4,536 kg	10,000 lbs.	4,536 kg	10,000 lbs.	4,536 kg

ROTATOR & FORK CAPACITY at 20 in. Load Center (500 mm)					
Model	Fork Class	Fork Size (W x T)			
		100 x 35 mm	100 x 40 mm	125 x 40 mm	125 x 45 mm
30G	II	1650 kg	1650 kg	1650 kg	1650 kg
40G	II	1740 kg	2200 kg	2200 kg	2200 kg
45G	II	1,950 kg	2,500 kg	2,500 kg	2,500 kg
55G	II	1,950 kg	2,500 kg	2,700 kg	2,700 kg
65G	III	–	–	2,800 kg	3,200 kg
80G	III	–	–	–	4000 kg
100G	III	–	–	–	4000 kg

Model	Fork Class	Fork Size (W x T)			
		125 x 50 mm	150 x 50 mm	150 x 65 mm	180 x 50 mm
80G	III	4000 kg	4000 kg	4000 kg	4000 kg
100G	III	4930 kg	5000 kg	5000 kg	5000 kg

100-Hour Maintenance

Every time the lift truck is serviced or every 100 hours of truck operation, whichever comes first, complete the following maintenance procedures:

- Check for loose or missing bolts, worn or damaged hoses, and hydraulic leaks.
- Check that fork locking pins and end bar keepers are installed and functional.
- Lubricate plungers on hydraulic or electronic 180-degree stop valves (if fitted).
- Check decals and nameplate for legibility.

500-Hour Maintenance

After each 500 hours of truck operation, in addition to the 100-hour maintenance, perform the following procedures:



WARNING: A sampling of faceplate and baseplate bearing assembly capscrows must be checked for proper torque at 500 hours (see TB183). A complete inspection is required every 2000 hours. Failure to keep the capscrows tightened can result in attachment damage and serious injury.

- Check sample of baseplate-to-bearing capscrows for proper torque value. See Technical Bulletin TB183 or Service Manual 6089468 (30G-40G) or Service Manual 6073955 (45G-100G) for checking and replacement procedures.
- Check sample of faceplate-to-bearing capscrows for proper torque value. See Technical Bulletin TB183 or Service Manual 6089468 (30G-40G) or Service Manual 6073955 (45G-100G) for checking and replacement procedures.
- Tighten lower mounting hook capscrows to a torque of:
 - CL II/III** – 120 ft.-lbs. (165 Nm)
 - CL IV** – 195 ft.-lbs. (265 Nm).
- Tighten rotator drive capscrows to a torque of:
 - 30G-40G** – 24 ft.-lbs. (32 Nm)
 - 45G-100G** – 75 ft.-lbs. (105 Nm)
- Lubricate rotation bearing assembly ball race **(A)**, and gear **(B)** with EP-2 grease (Whitmore 'Omnitask' or equivalent). Rotate in 90-degree increments and grease in each position.
- Check rotator drive gearcase lubricant level.
 - 30G-40G** – Lubricant should be filled up to the end cover level hole. Add lubricant through the top fill hole.
 - 45G-100G** – Lubricant should be filled up to the end cover hole. Add lubricant through the end cover hole.

If necessary, fill with Cascade Rotator Drive Lubricant, Part No. 656300, or SAE 90 wt. gear lube (AGMA 'mild' 6 EP Gear Oil). Replace plug.



WARNING: After completing any service procedure, always test the Rotator through five complete cycles. First test empty, then test with a load to make sure the Rotator operates correctly before returning it to the job.

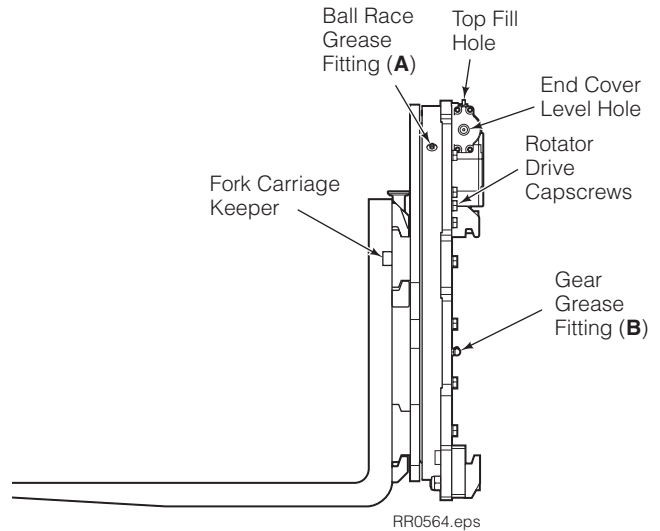

30G-40G
Left Side

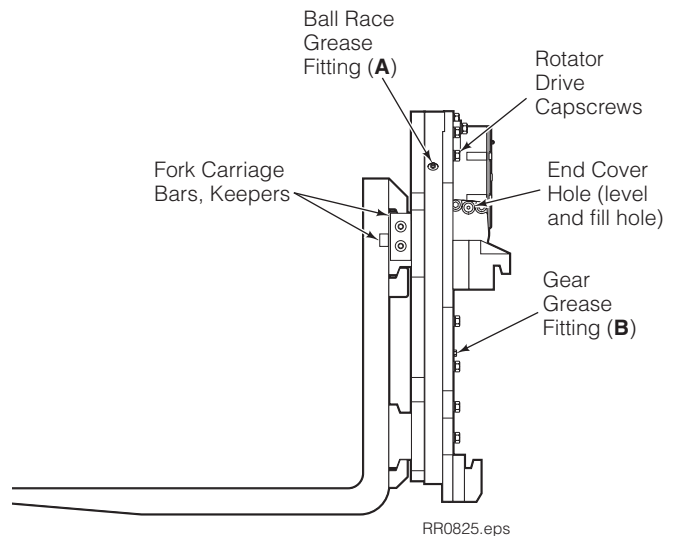

45G-100G
Left Side

1000-Hour Maintenance

After each 1000 hours of truck operation, in addition to the 100 and 500-hour maintenance, perform the following procedures:

- Change 30G/40G rotator drive gearcase lubricant. Drain oil out the bottom case hole. Refer to Service Manual 6089468 for service. Fill through top fill hole up to the end cover level hole. Use Cascade Rotator Drive Lubricant, Part No. 656300, or SAE 90 wt. gear lube (AGMA 'mild' 6 EP Gear Oil). Replace plug.

2000-Hour Maintenance

After each 2000 hours of truck operation, in addition to the 100, 500 and 1000-hour maintenance, perform the following procedures:

- Check **all** rotation bearing capscrews for proper torque value. See Technical Bulletin TB183 or Service Manual 6089468 (30G–40G) or Service Manual 6073955 (45G–100G) for checking and replacement procedures.
- Inspect forks and carriage bars for wear.

NOTE: Cascade fork safety kit 3014162 available with wear calipers, inspection sheets and safety poster. Also available Cascade fork hook & carriage bar wear gauge 209560 (CL II), 209561 (CL III).

- Check 30G/40G rotator drive gearcase lubricant level. Lubricant should be filled up to end cover level hole. If necessary, fill with Cascade Rotator Drive Lubricant, Part No. 656300, or SAE 90 wt. gear lube (AGMA 'mild' 6 EP Gear Oil). Replace top plug.

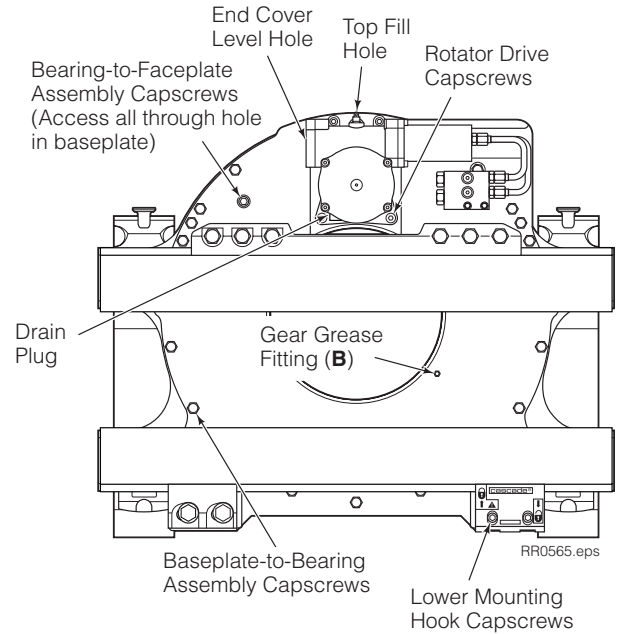

30G-40G
Back (Driver's) View

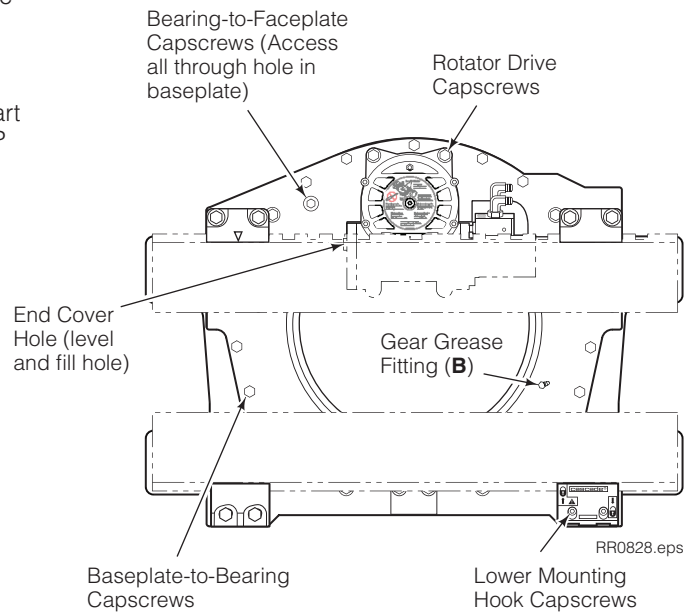

45G-100G
Back (Driver's) View

Do you have questions you need answered right now? Call your nearest Cascade Service Department. Visit us online at www.cascorp.com

AMERICAS

**Cascade Corporation
U.S. Headquarters**
2201 NE 201st
Fairview, OR 97024-9718
Tel: 800-CASCADE (227-2233)
Fax: 888-329-8207

Cascade Canada Inc.
5570 Timberlea Blvd.
Mississauga, Ontario
Canada L4W-4M6
Tel: 905-629-7777
Fax: 905-629-7785

Cascade do Brasil
Rua João Guerra, 134
Macuco, Santos - SP
Brasil 11015-130
Tel: 55-13-2105-8800
Fax: 55-13-2105-8899

EUROPE-AFRICA

**Cascade Italia S.R.L.
European Headquarters**
Via Dell'Artigianato 1
37050 Vago di Lavagno (VR)
Italy
Tel: 39-045-8989111
Fax: 39-045-8989160

Cascade (Africa) Pty. Ltd.
PO Box 625, Isando 1600
60A Steel Road
Sparton, Kempton Park
South Africa
Tel: 27-11-975-9240
Fax: 27-11-394-1147

ASIA-PACIFIC

Cascade Japan Ltd.
2-23, 2-Chome,
Kukuchi Nishimachi
Amagasaki, Hyogo
Japan, 661-0978
Tel: 81-6-6420-9771
Fax: 81-6-6420-9777

Cascade Korea
121B 9L Namdong Ind.
Complex, 691-8 Gojan-Dong
Namdong-Ku
Inchon, Korea
Tel: +82-32-821-2051
Fax: +82-32-821-2055

Cascade-Xiamen
No. 668 Yangguang Rd.
Xinyang Industrial Zone
Haicang, Xiamen City
Fujian Province
P.R. China 361026
Tel: 86-592-651-2500
Fax: 86-592-651-2571

**Cascade India Material
Handling Private Limited**
No 34, Global Trade Centre
1/1 Rambaugh Colony
Lal Bahadur Shastri Road,
Navi Peth, Pune 411 030
(Maharashtra) India
Phone: +91 020 2432 5490
Fax: +91 020 2433 0881

Cascade Australia Pty. Ltd.
1445 Ipswich Road
Rocklea, QLD 4107
Australia
Tel: 1-800-227-223
Fax: +61 7 3373-7333

Cascade New Zealand
15 Ra Ora Drive
East Tamaki, Auckland
New Zealand
Tel: +64-9-273-9136
Fax: +64-9-273-9137

**Sunstream Industries
Pte. Ltd.**
18 Tuas South Street 5
Singapore 637796
Tel: +65-6795-7555
Fax: +65-6863-1368

