

Technical Bulletin

D & E-Series Carton Clamp Filler Block Edge Guard

This sheet describes the retrofit of leading edge guards to the plastic filler blocks on Cascade Carton Clamp contact pads.

- 1 Remove the four front capscrews fastening the plastic filler blocks to the contact pad. Rear capscrews need only be loosened as necessary.
- 2 Insert the steel edge guard (Part No. 6024953) between the filler blocks and the contact pad. Replace the capscrews with new capscrews (Part No. 768697).
- 3 Tighten capscrews to 18 ft.-lbs. (25 Nm).

CAUTION: Do not overtighten capscrews or filler blocks may be damaged.

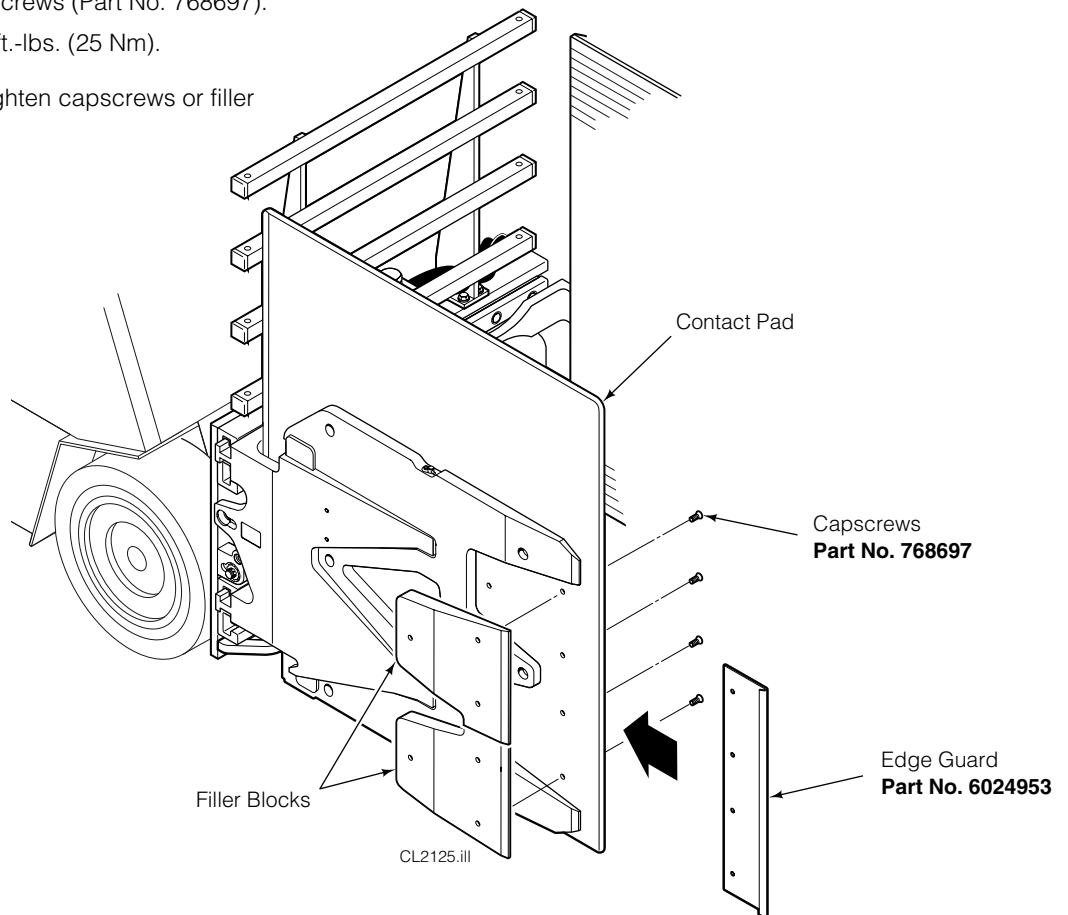

NOTE: This information should not be interpreted as the basis for warranty claims unless so designated.

cascade[®]
corporation

For Technical Support . . .

Call: 1-800-227-2233 Fax: 1-888-329-8207
Internet: www.cascorp.com
Write: Cascade Corporation, PO Box 20187, Portland, OR 97294

To Order Parts . . .

Call: 1-888-227-2233 Fax: 1-888-329-0234
Internet: www.cascorp.com
Write: Cascade Corporation, 2501 Sheridan Ave., Springfield, OH 45505