



Installation Instructions

Lockout Plate 6029272 to Prevent Installing a Push/Pull or Rug Poles on Reach Trucks

These instructions describe how to install lockout plate 6029272 on the carriage of reach type lift trucks to prevent the installation of a Push/Pull or Rug Poles. A Push/Pull or Rug Pole should never be installed on a reach type truck.

- 1** Position the lockout plate centered on the upper carriage bar of either the sideshifter or carriage.
- 2** Mark the area to be welded on both sides of the lockout plate. Remove paint and grease from the weld area. Protect adjacent components from weld splatter.
- 3** Weld the lockout plate using FCAW (Flux-Cored Arc Weld). Attach the ground wire to the carriage. Weld using AWS E70T-1 1/16 in. (1.6 mm) or 5/64 in. (2 mm) diameter wire with 100% CO² shielding gas at 35–50 CFH. Set welding amps per manufacturer's recommendations. Apply weld holding a close arc. Do not oscillate or use a wash bead pattern. Let welds normal air-cool.
- 4** Clean the weld area and repaint.

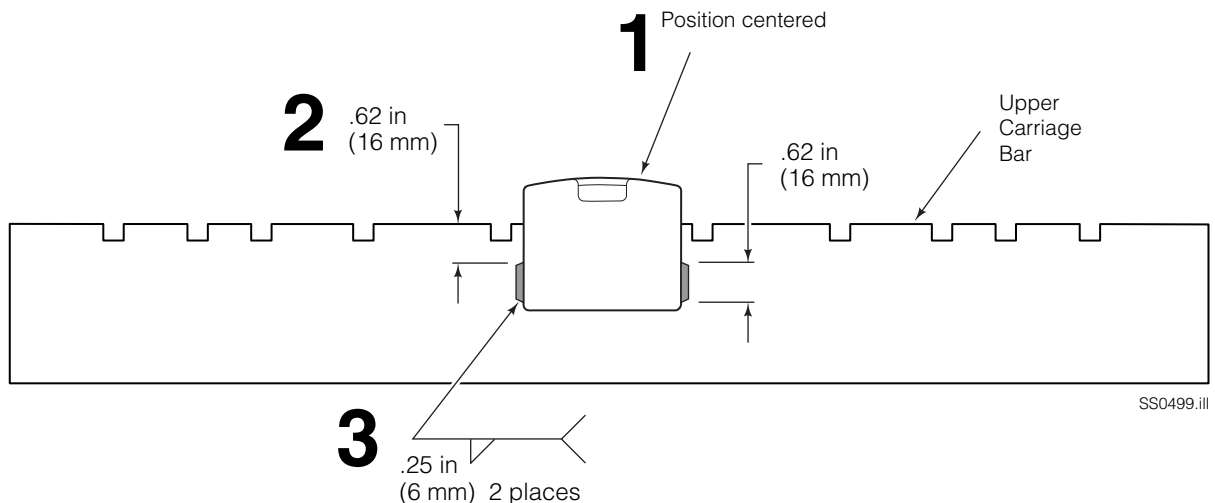
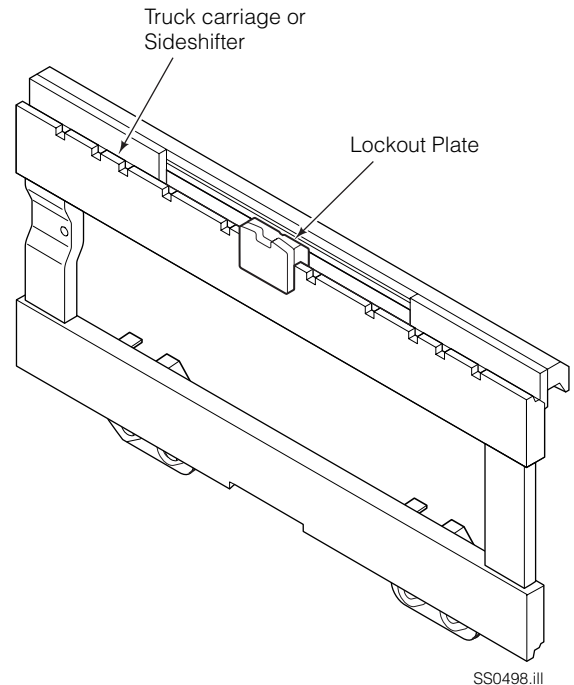

Part No. 6029294

cascade[®]
corporation

For Technical Support . . .

Call: 1-800-227-2233 Fax: 1-888-329-8207
Internet: www.cascorp.com
Write: Cascade Corporation, PO Box 20187, Portland, OR 97294

To Order Parts . . .

Call: 1-888-227-2233 Fax: 1-888-329-0234
Internet: www.cascorp.com
Write: Cascade Corporation, 2501 Sheridan Ave., Springfield, OH 45505