

0 *PERATOR'S GUIDE*

35E *QFM,TM*
45E *Push/Pull and*
Load Push

No. 684945-R4 EN

cascade[®]
corporation

Cascade is a registered Trademark of Cascade Corporation

C ONTENTS

Introduction	i
Safety Rules	1
Daily Inspection	2
Attachment Operation	2
Slipsheet Loads	3
Loads with Torn Slipsheet Tabs	3
Loading	4
Loading from Floor	4
Loading from Pallets	4
Loading from Stacks	5
Loading from Truck Trailers	5
Unloading	6
Unloading on Stacks	6
Unloading on Pallets	6
Pallet Boards In Line with Push Direction	6
Unloading on Pallets	7
Pallet Boards Opposite Push Direction	7
Unloading into Truck Trailers	7
Sheet-Sav® Operation	8
Attachment Removal – QFM™	8
Attachment Installation – QFM™	9
Platen Adjustment	9
Faceplate Stop Adjustment	10
Safe Operation and Maintenance	11
OSHA Regulations	11



WARNING: Rated capacity of the truck/ attachment combination is a responsibility of the original truck manufacturer and may be less than shown on the attachment nameplate. Consult the truck nameplate.

WARNING: Do not operate this attachment unless you are a **trained and authorized** lift truck driver.

INTRODUCTION

This guide contains operating instructions for **cascade® 35E/45E Load Push/Pulls**. It will help avoid common errors which often cause damage to the equipment or loads being handled.

Read this manual thoroughly before operating the attachment. Be sure you know and understand all operating procedures and safety precautions. If you have any questions or don't understand a procedure ask your supervisor.

Emphasize Safety! Most accidents are caused by operator carelessness or misjudgement. You must watch for hazardous situations and correct them.

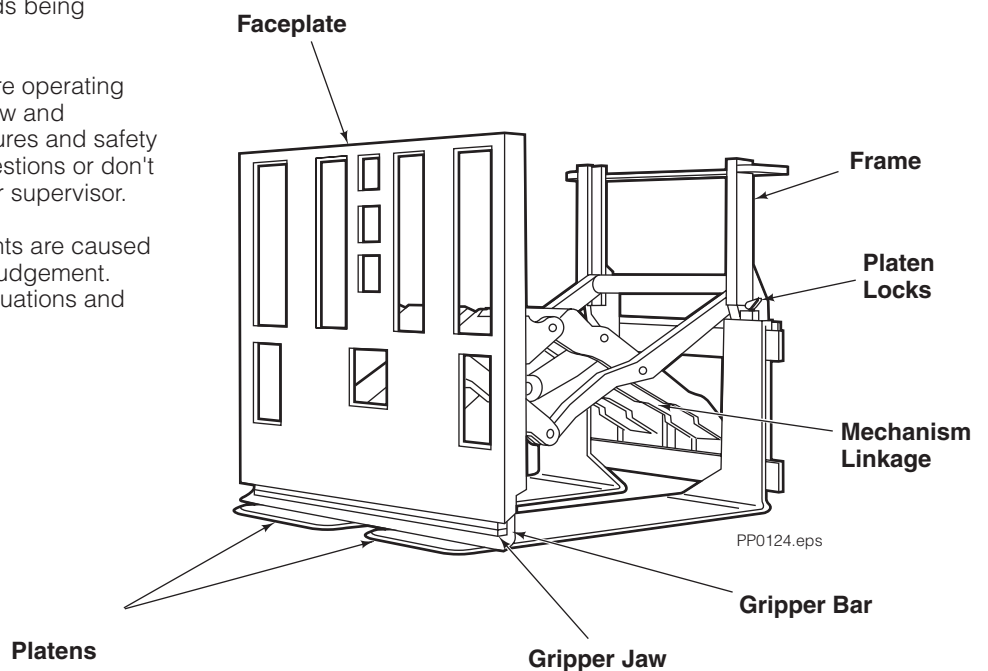

S SAFETY RULES

No riders



No reach through mast



No underload



PP0125.eps

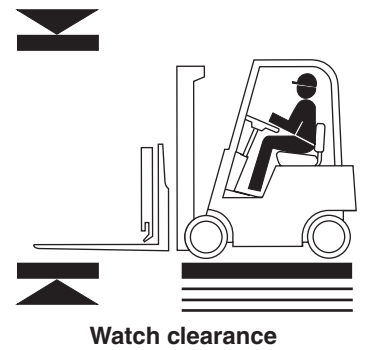
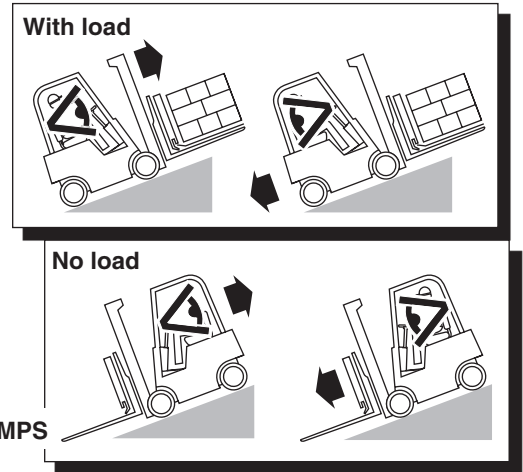
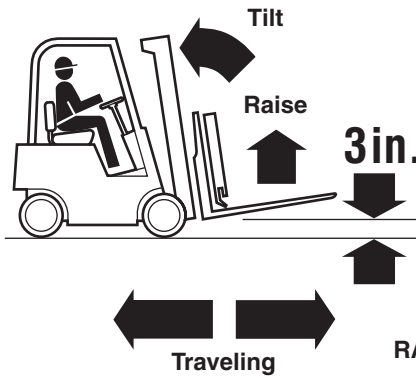

PP0383.eps

TRAFFIC					
Observe	Workers	Stops			
Wet floors	Bumps	Dips	Slow for two way traffic	Sound horn, slow at intersection	Sound horn, slow at corner

DAILY INSPECTION

Check items each day. Report problems to your supervisor. See Service Manual 686455 for maintenance and repair procedures.

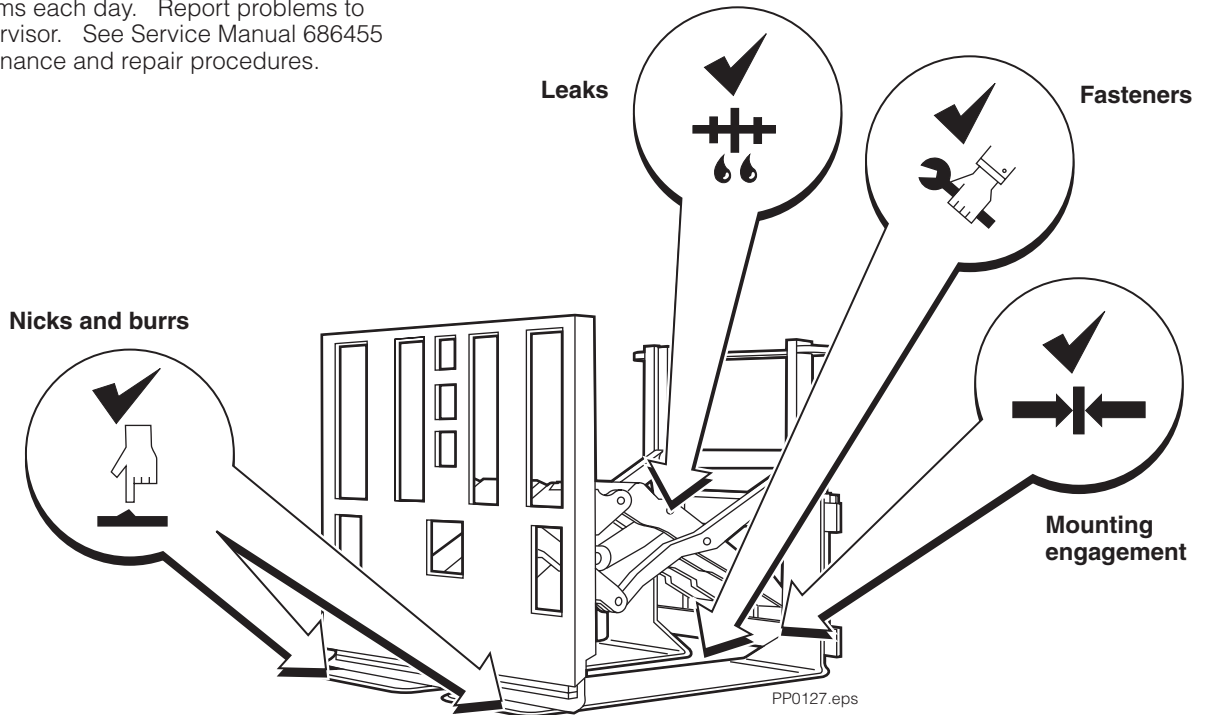

ATTACHMENT OPERATION

SOLENOID EQUIPPED ATTACHMENTS

PUSH/PULL LOAD PUSH

- A Sideshift left
- A Faceplate push (press knob button)
- A Position platens-out (press button)
- B Sideshift right
- B Faceplate retract/pull (press button)
- B Position platens-in (press button)
- C Not used
- D Not used

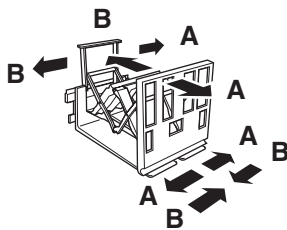

PUSH/PULL WITH SIDESHIFT LOAD PUSH WITH SIDESHIFT

- A Sideshift left
- B Sideshift right
- C Faceplate push
- D Facplate retract/pull

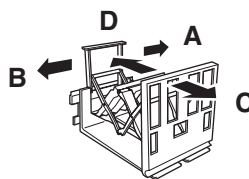

PUSH/PULL WITH SHEET-SAV®

- A Sideshift left
- B Sideshift right
- C Faceplate push
- C Sheet-Sav®-lift (press button)
- D Faceplate retract/pull
- D Sheet-Sav®-retain (press button)

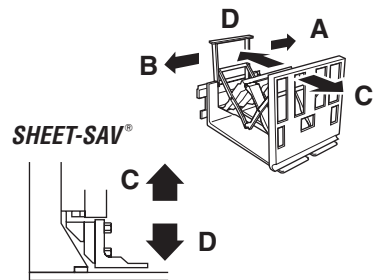

PUSH/PULL LOAD PUSH

- A Facplate push
- B Faceplate retract/pull
- C Not used
- D Not used

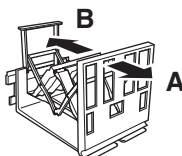

PP0128.eps

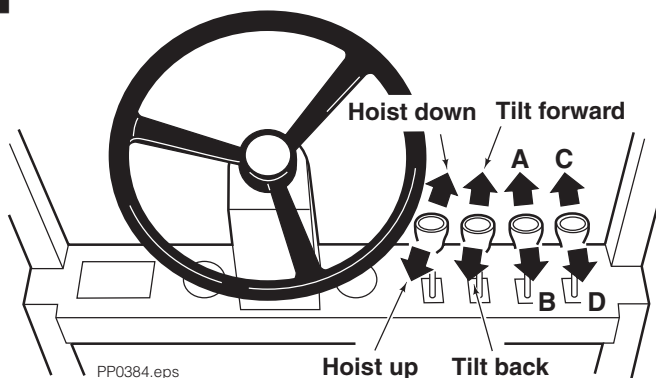

PP0384.eps

S LIPSHEET LOADS

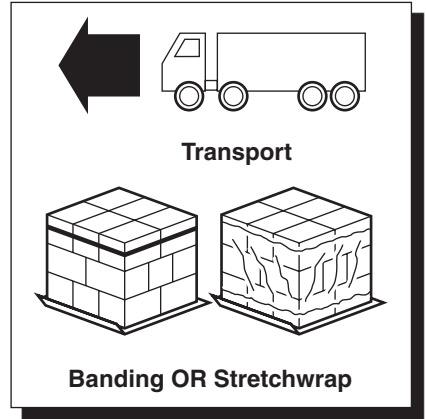
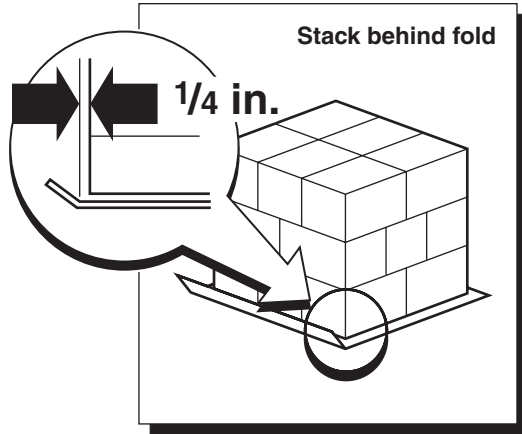

PP0129.eps

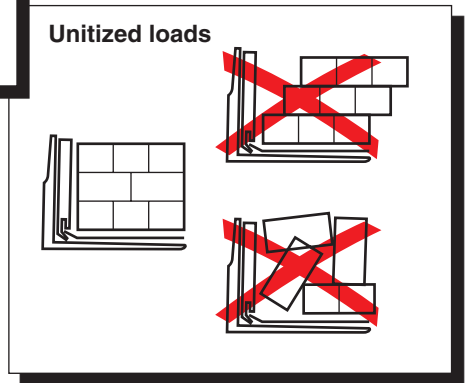
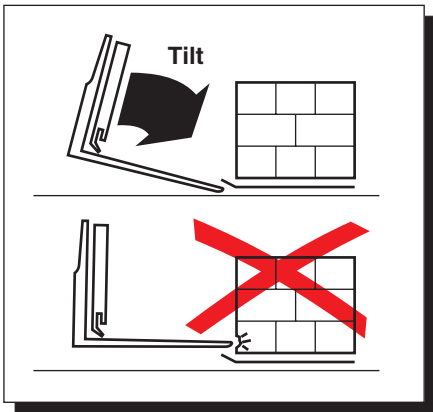

Loads with Torn Slipsheet Tab

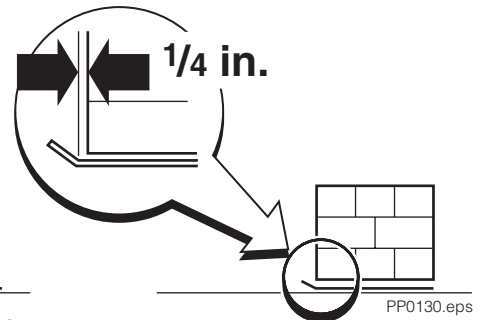
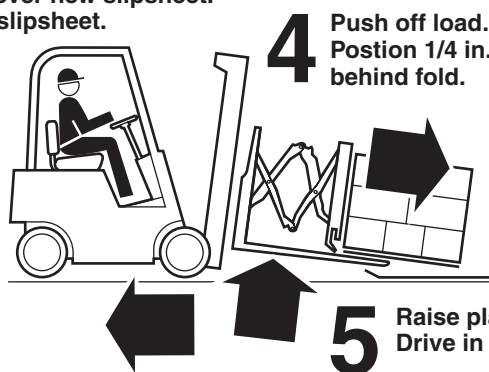
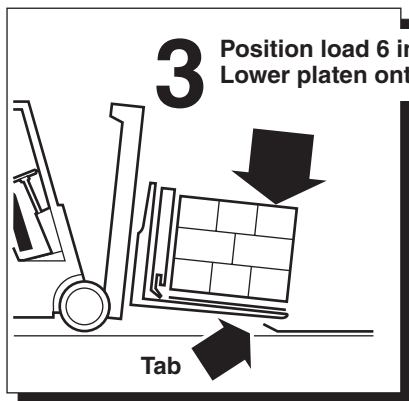
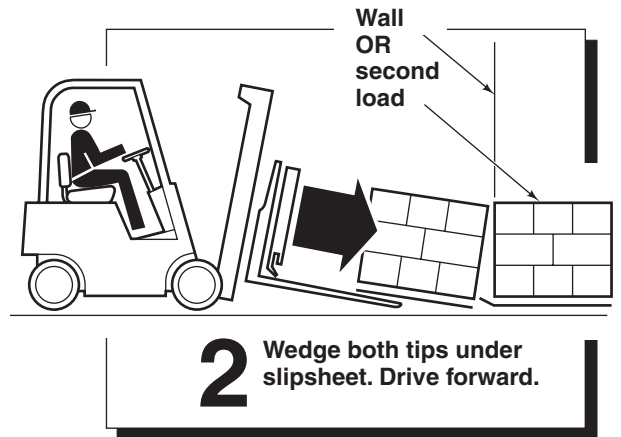
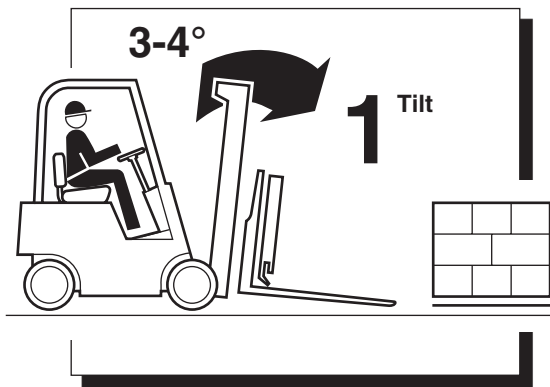

PP0130.eps

LOADING FROM FLOOR

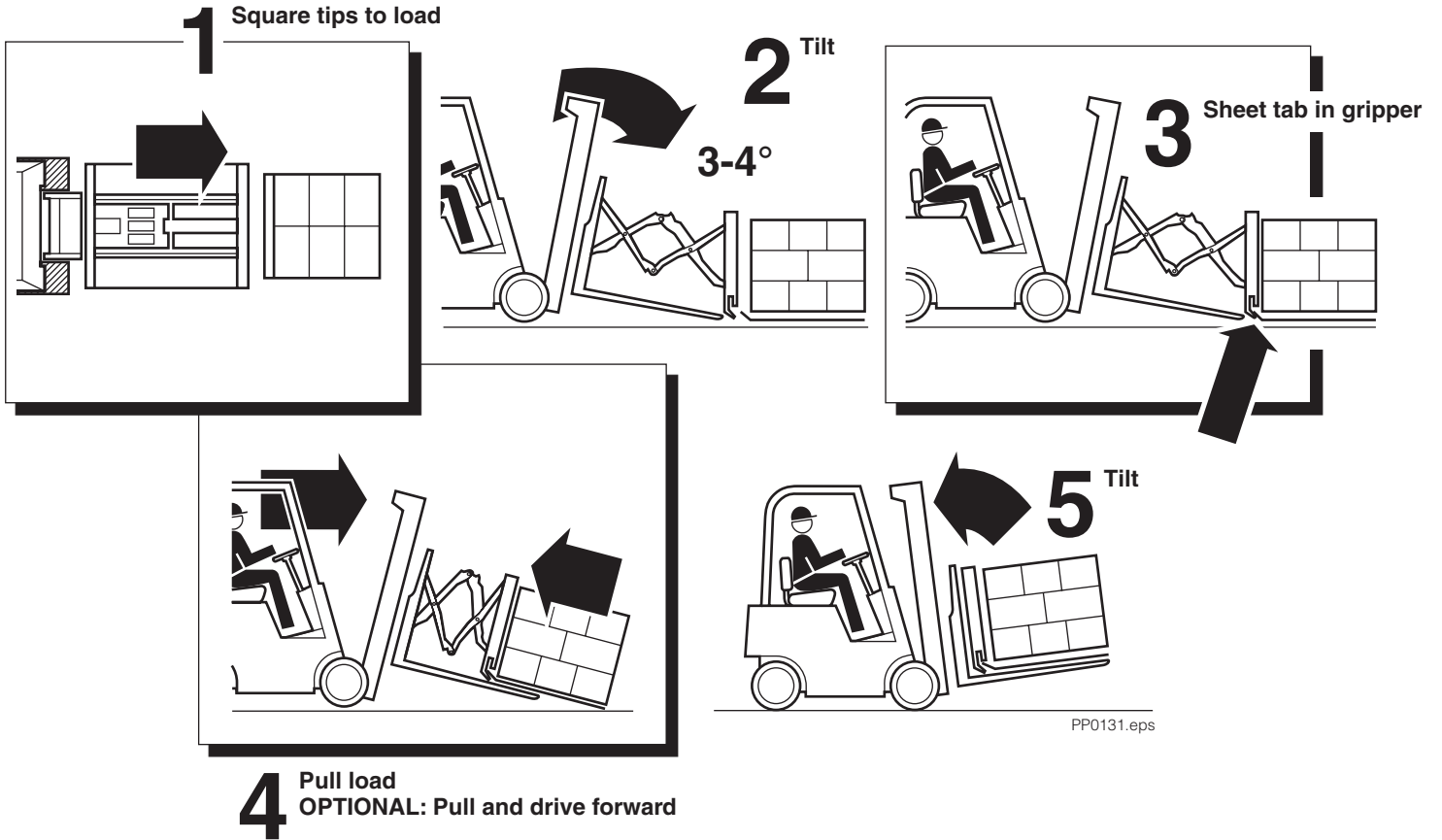

LOADING FROM PALLETS

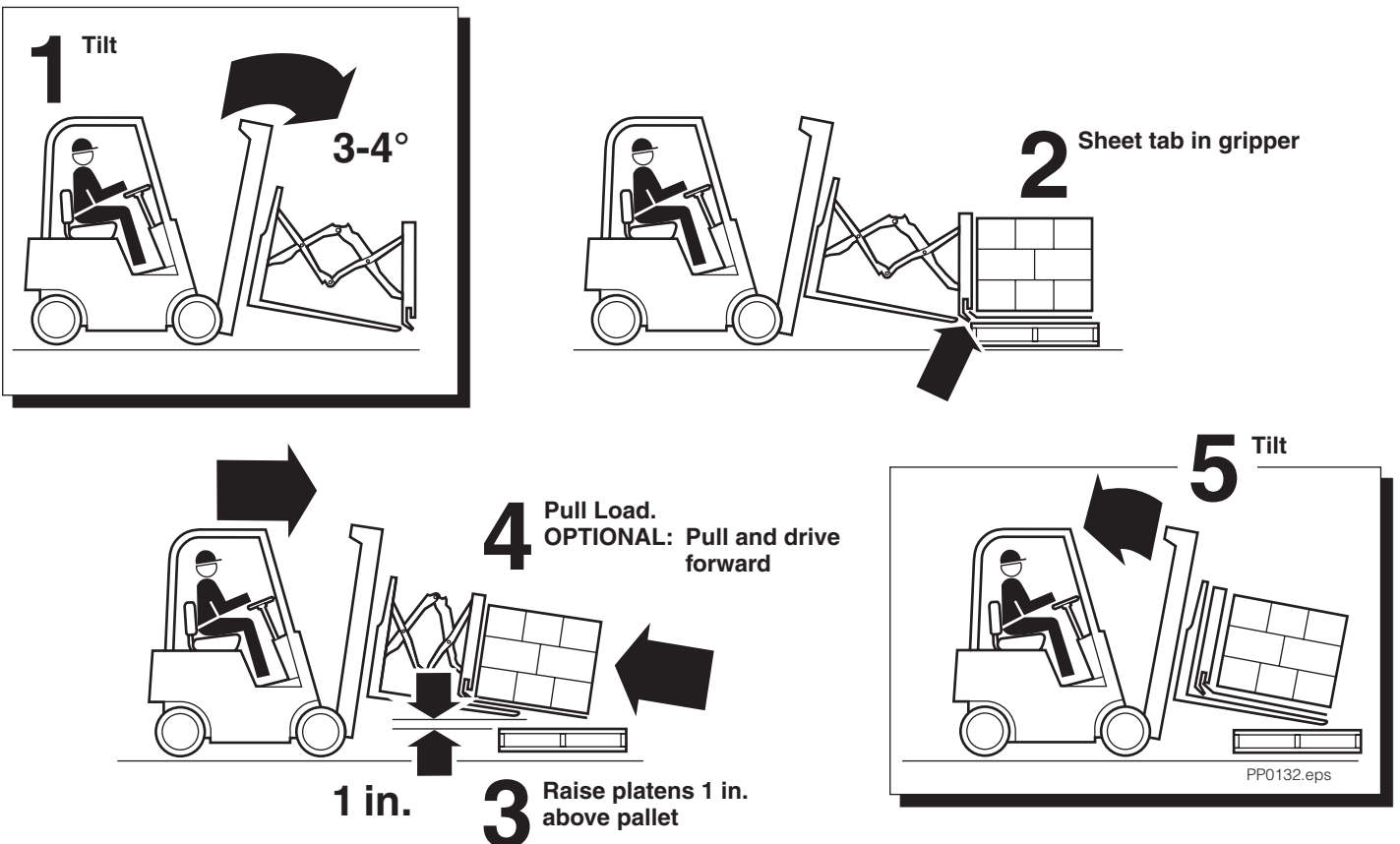

L OADING FROM STACKS

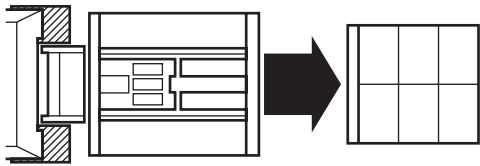

1 Square tips to load

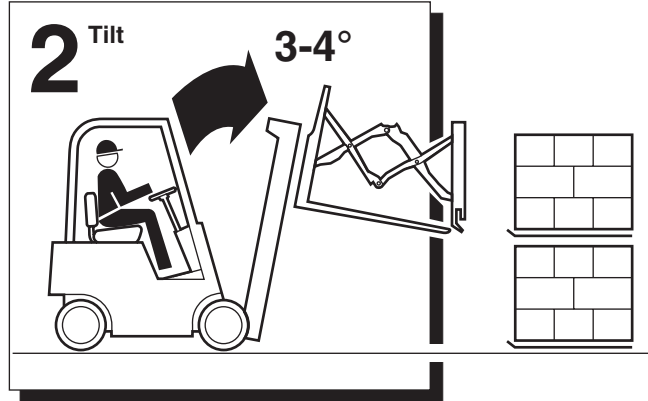

2 Tilt 3-4°

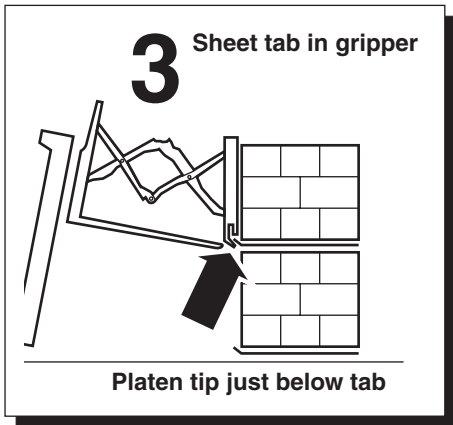

3 Sheet tab in gripper

Platen tip just below tab

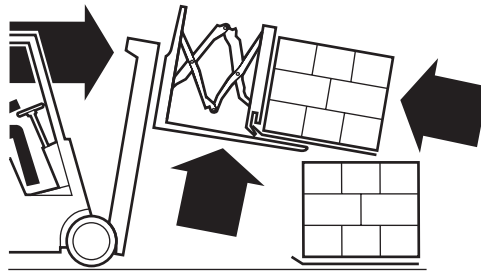

4 Pull load
OPTIONAL: Pull and drive forward.
Raise platens as load is pulled on.

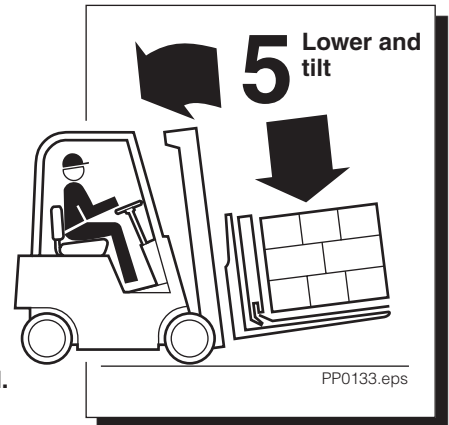

5 Lower and tilt

PP0133.eps

L OADING FROM TRUCK TRAILERS

CAUTION: Level trailer with dock. Watch for nails or screws on trailer floor and walls.

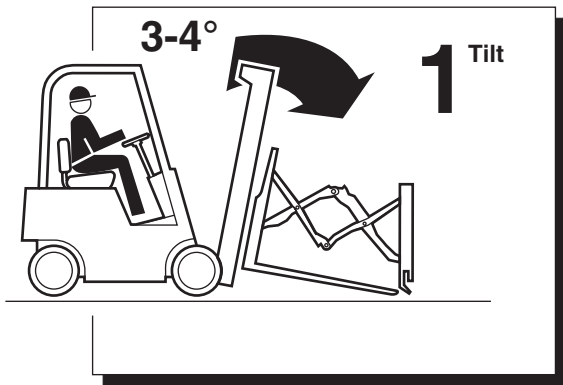

3-4° **1** Tilt

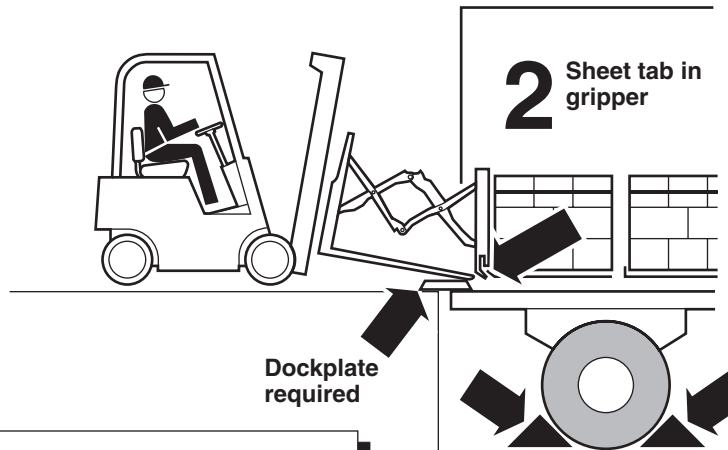

2 Sheet tab in gripper

Dockplate required

CAUTION: Trailer wheels must be locked

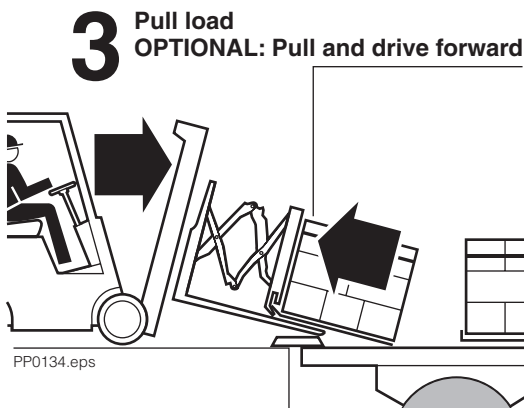

3 Pull load
OPTIONAL: Pull and drive forward

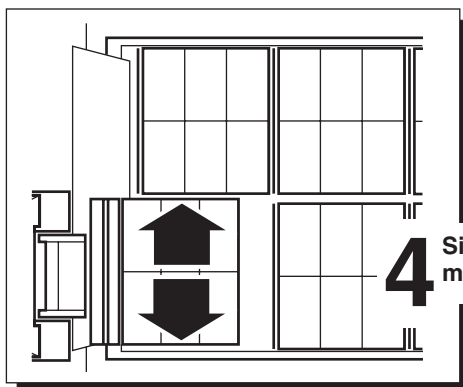

4 Sideshift to square load and make room for removal

PP0134.eps

UNLOADING ON STACKS

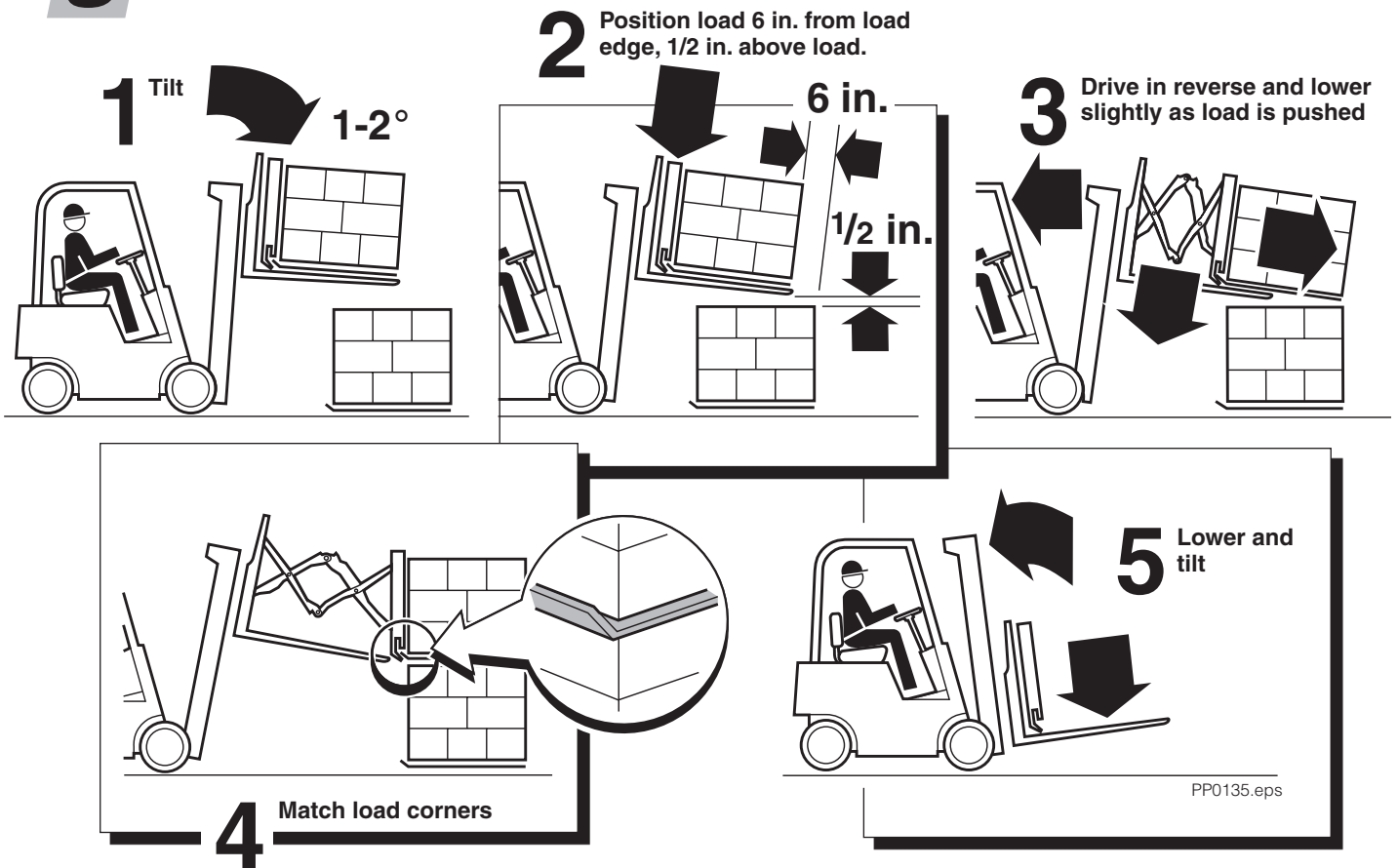

UNLOADING ON PALLETS

Pallet Boards in line with Push Direction

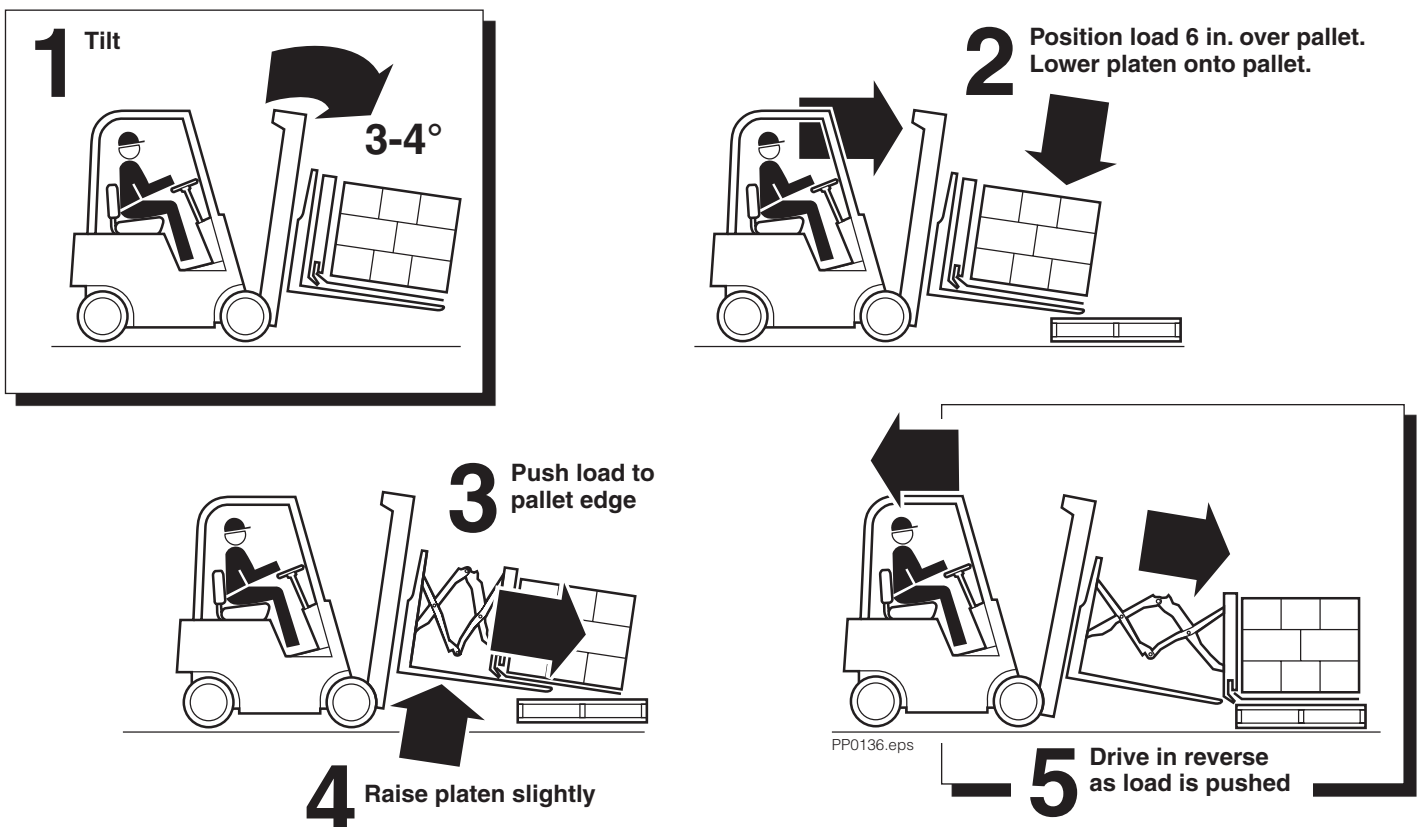

UNLOADING ON PALLETS

Pallet Boards Opposite Push Direction

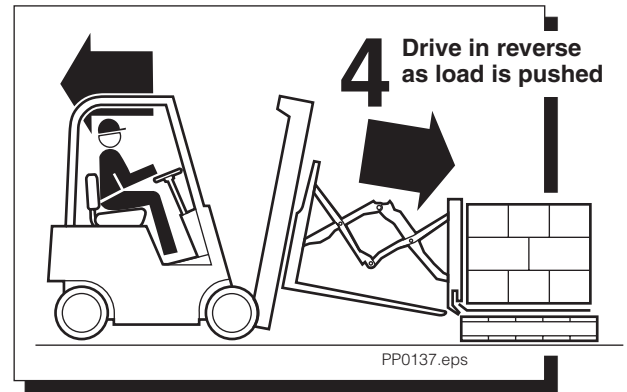
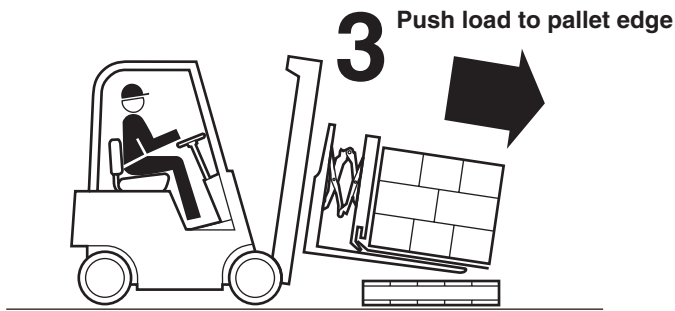
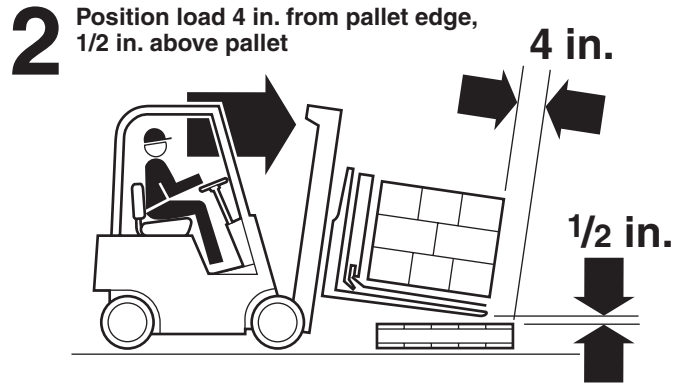
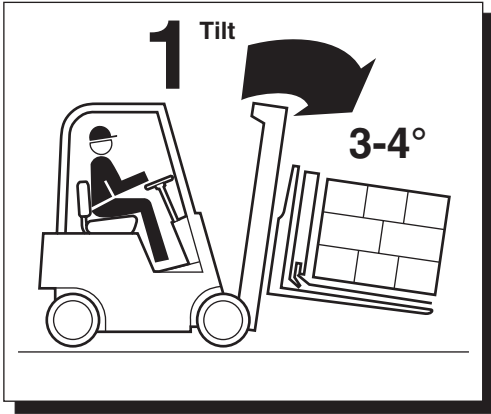

UNLOADING INTO TRUCK TRAILERS

CAUTION: Level trailer with dock. Watch for nails or screws on trailer floor and walls.

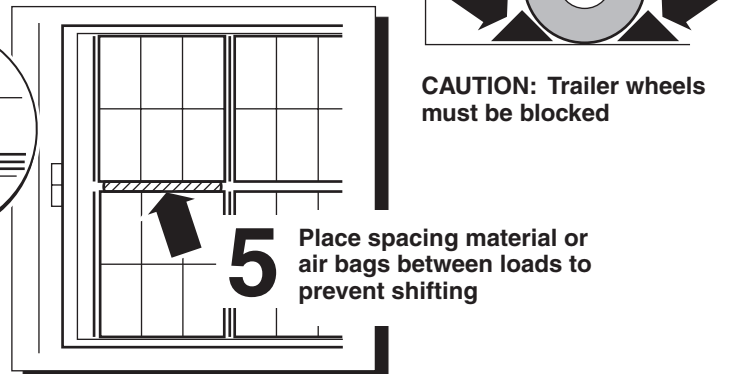
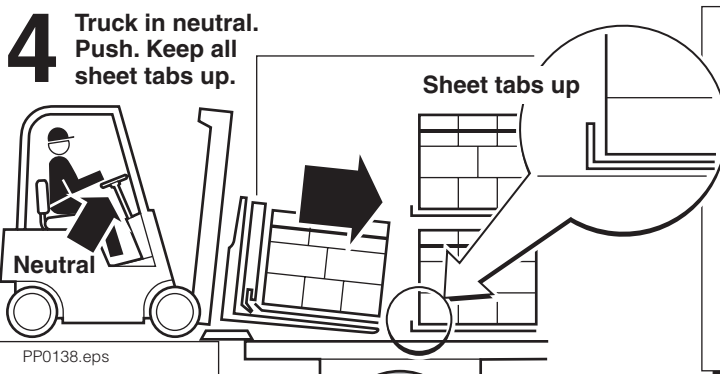
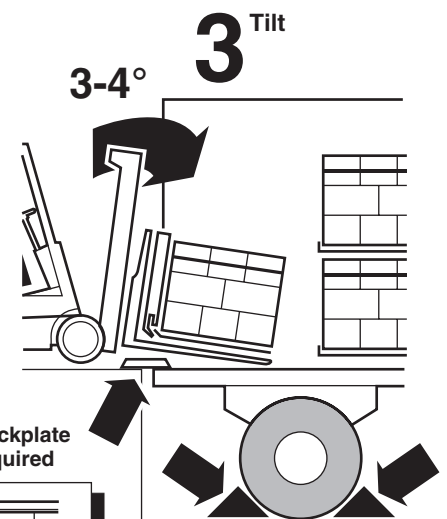
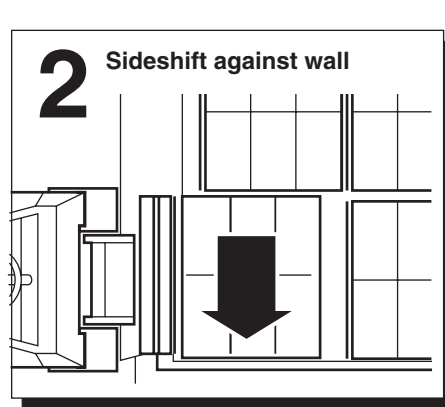
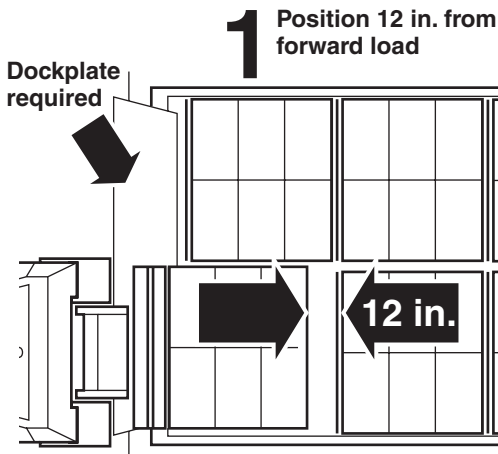

SHEET-SAV[®] OPERATION

1 Pull load
OPTIONAL: Pull and drive forward

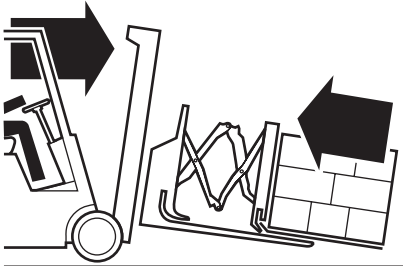

2 Raise Sheet-Sav[®] foot.
Sheet tab positions
under foot

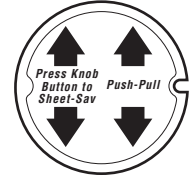
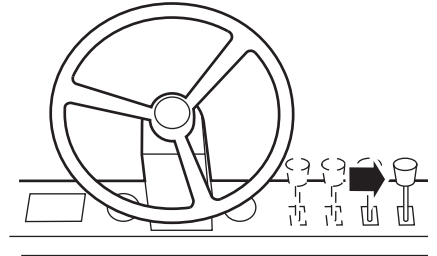
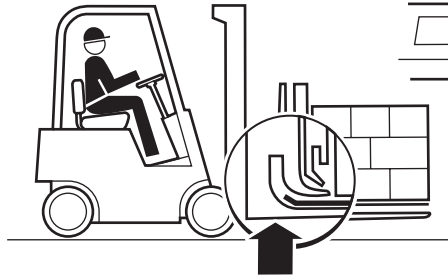

3 Lower Sheet-Sav[®] foot.



PP0139.eps

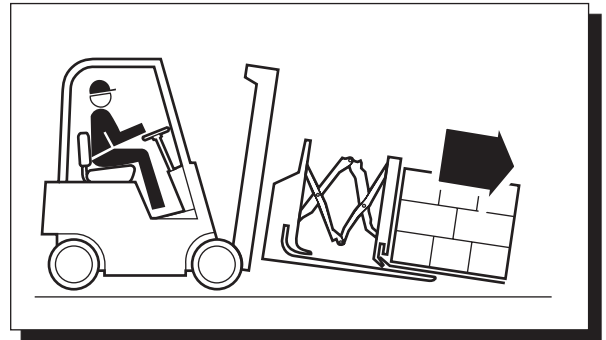

A TTACHMENT REMOVAL QFM[™] (Quick Fork Mount) Attachments

1 Extend faceplate and raise

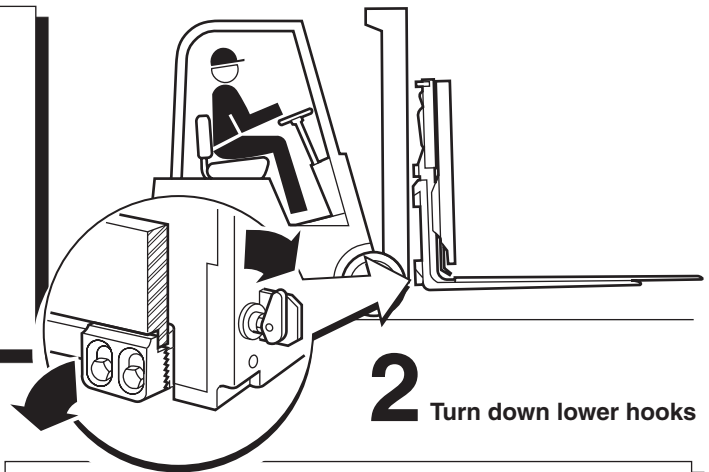
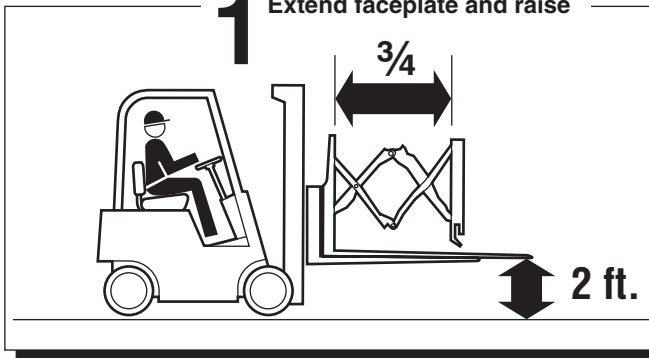

2 Turn down lower hooks

3 Quick
disconnect
couplers

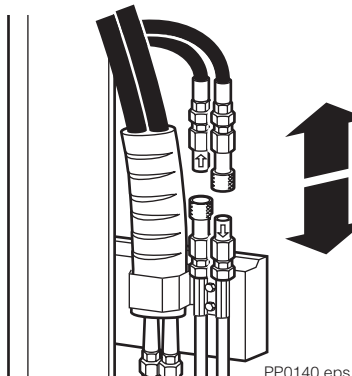

PP0140.eps

4 Back away

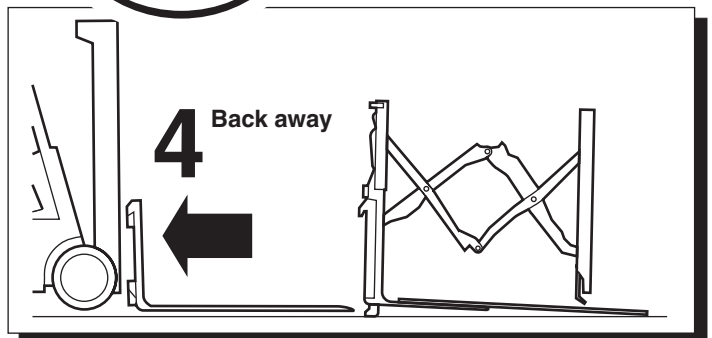

A TTACHMENT INSTALLATION

QFM™ (Quick Fork Mount) Attachments

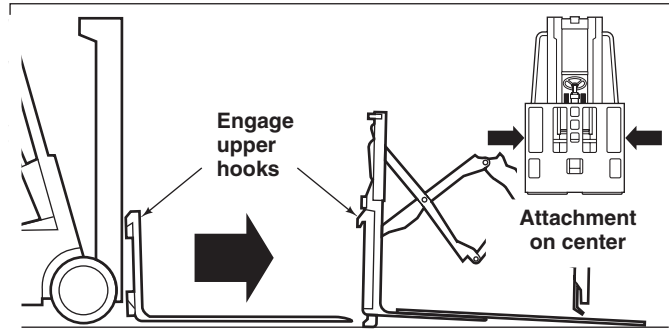
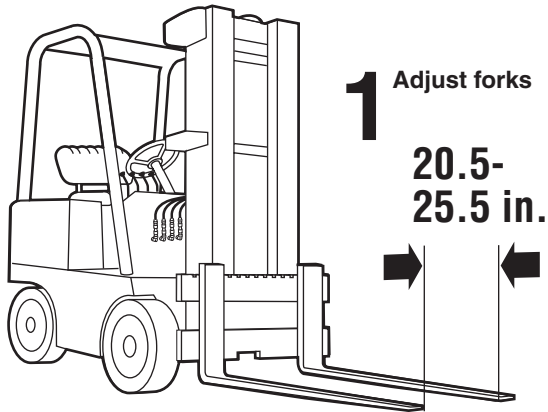

2 A Drive forks under attachment
B Engage upper forks

3 A Turn up lower hooks
B Adjust hook clearance and tighten

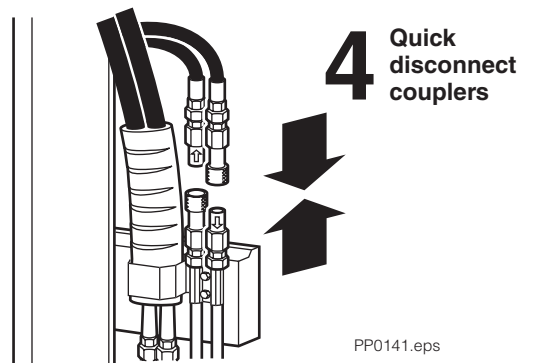
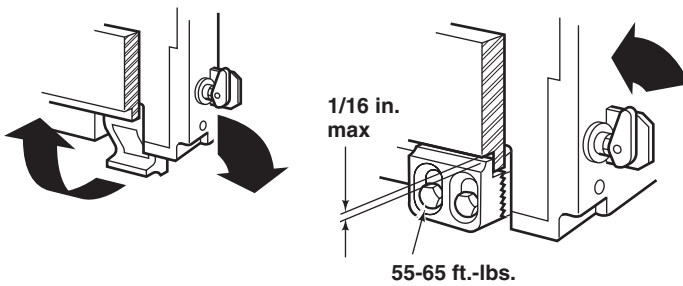

P LATEN ADJUSTMENT

Dedicated Attachments

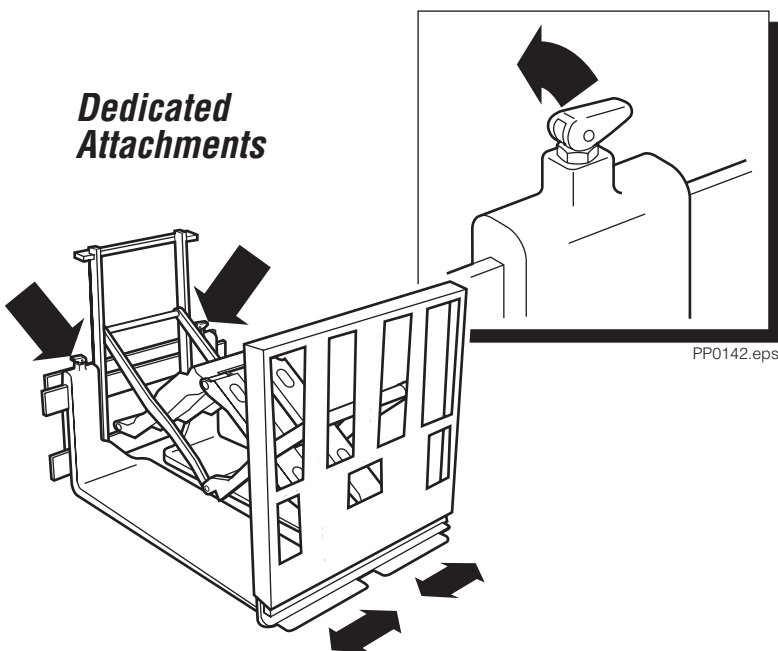

QFM™ (Quick Fork Mount) Attachments

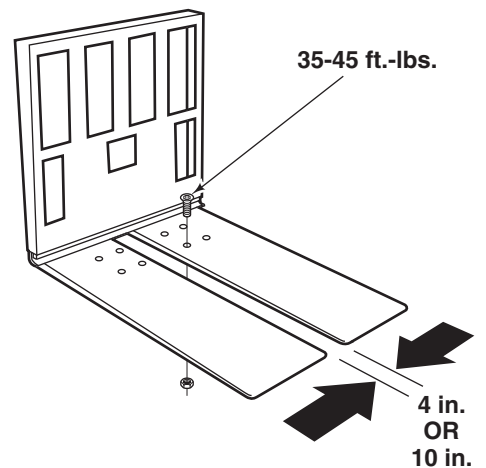

FACEPLATE STOP ADJUSTMENT

Attachments equipped with faceplate stop option

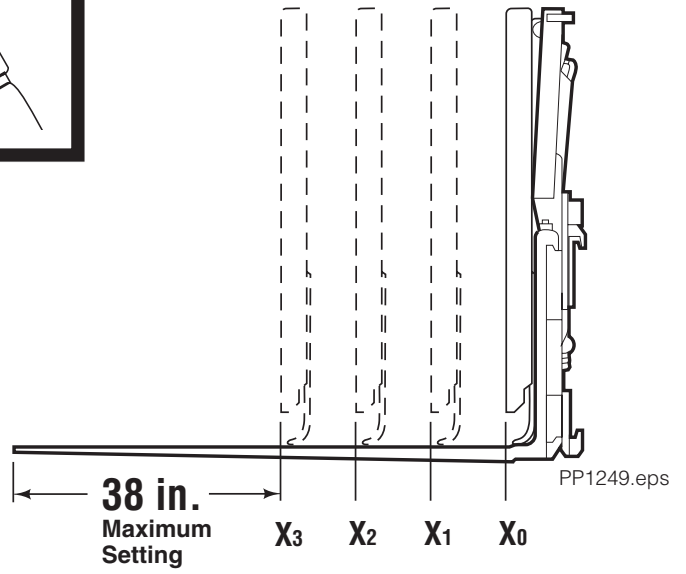
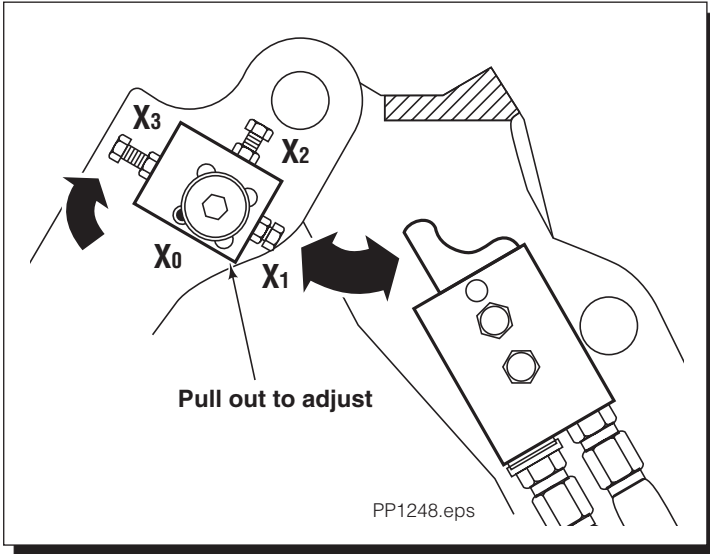



WARNING: When operating and maintaining industrial trucks equipped with attachments you should pay particular attention to the following information. You should be familiar with **all** of these sections.

General Requirement

Modifications and additions which affect capacity and safe operation shall not be performed by the customer or user without manufacturers prior written approval. Capacity, operation and maintenance instruction plates, tags or decals shall be changed accordingly.

If the truck is equipped with front-end attachments other than factory installed attachments, the user shall request that the truck be marked to identify the attachments and show the appropriate weight of the truck and attachment combination at maximum elevation with load laterally centered.

The user shall see that all nameplates and markings are in place and maintained in a legible condition.

Safety Guards

If the type of load presents a hazard, the user shall equip fork trucks with a vertical load backrest extension in accordance with the following.

All new powered industrial trucks acquired and used by an employer after February 15, 1972 shall meet the design and construction requirements for powered industrial trucks established in the "American National Standard for Powered Industrial Trucks, Part II, ANSI B56.1", except for vehicles intended primarily for earth moving or over-the-road hauling.

Operator Training

Only trained and authorized operators shall be permitted to operate a powered industrial truck. Methods shall be devised to train operators in the safe operation of powered industrial trucks.

Truck Operations

Trucks shall not be driven up to anyone standing in front of a bench or other fixed object.

No person shall be allowed to stand or pass under the elevated portion of any truck, whether loaded or empty.

Unauthorized personnel shall not be permitted to ride on powered industrial trucks. A safe place to ride shall be provided where riding of trucks is authorized.

The employer shall prohibit arms or legs from being placed between the uprights of the mast or outside the running lines of the truck.

When a powered industrial truck is left unattended, load engaging means shall be fully lowered, controls shall be neutralized, power shall be shut off and brakes set. Wheels shall be blocked if the truck is parked on an incline.

A powered industrial truck is unattended when the operator is 25 feet or more away from the vehicle which remains in his view, or whenever the operator leaves the vehicle and it is not in his view.

When the operator of an industrial truck is dismounted and within 25 feet of the truck still in his view, the load engaging means shall be fully lowered, controls neutralized and the brakes set to prevent movement.

A safe distance shall be maintained from the edge of ramps or platforms while on any elevated dock or platform or freight car. Trucks shall not be used for opening or closing freight doors.

A load backrest extension shall be used whenever necessary to minimize the possibility of the load or part of it from falling rearward.

Traveling

The driver shall be required to slow down and sound the horn at cross isles and other locations where vision is obstructed. If the load being carried obstructs forward view, the driver shall be required to travel with the load trailing.

When ascending or descending grades in excess of 10 percent, loaded trucks shall be driven with the load upgrade.

On all grades the load and load engaging means shall be tilted back if applicable, and raised only as far as necessary to clear the road surface.

Loading

Only stable or safely arranged loads shall be handled. Caution shall be exercised when handling off-center loads which cannot be centered.

Only loads within the rated capacity of the truck shall be handled.

The long or high (including multiple-tiered) loads which may affect capacity shall be adjusted.

Trucks equipped with attachments shall be operated as partially loaded trucks when not handling a load.

A load engaging means shall be placed under the load as far as possible; the mast shall be carefully tilted backward to stabilize the load.

Extreme care shall be used when tilting the load forward or backward, particularly when high tiering. Tilting forward with load engaging means elevated shall be prohibited except to pick up a load. An elevated load shall not be tilted forward except when the load is in a deposit position over a rack or stack. When stacking or tiering, only enough backward tilt to stabilize the load shall be used.

Operation of the Truck

If at any time a powered industrial truck is found to be in need of repair, defective, or in any way unsafe, the truck shall be taken out of service until it has been restored to safe operating condition.

Maintenance of Industrial Trucks

Any power-operated industrial truck not in safe operating condition shall be removed from service. All repairs shall be made by authorized personnel.

All parts of any such industrial truck requiring replacement shall be replaced only by parts equivalent as to safety with those used in the original design.

Industrial trucks shall not be altered so that the relative positions of the various parts are different from what they were when originally received from the manufacturer, nor shall they be altered either by the addition of extra parts not provided by the manufacturer or by the elimination of any parts. Additional counter-weighting of fork trucks shall not be done unless approved by the truck manufacturer.

Industrial trucks shall be examined before being placed in service and shall not be placed in service if the examination shows any condition adversely affecting the safety of the vehicle. Such examinations shall be made at least daily. When industrial trucks are used on a round-the-clock basis, they shall be examined after each shift. Defects when found shall be immediately reported and corrected.

Do you have questions you need answered right now? Call your nearest Cascade Service Department. Visit us online at www.cascorp.com

Zijn er vragen waarop u direct een antwoord nodig hebt? Neem dan contact op met uw dichtstbijzijnde serviceafdeling van Cascade. Of ga naar www.cascorp.com

Haben Sie Fragen, für die Sie sofort eine Antwort benötigen? Wenden Sie sich an Ihren nächsten Cascade-Kundendienst. Besuchen Sie uns online: www.cascorp.com

En cas de questions urgentes, contacter le service d'entretien Cascade le plus proche. Visiter le site Web www.cascorp.com.

Per domande urgenti contattare l'Ufficio Assistenza Cascade più vicino. Visitate il nostro sito all'indirizzo www.cascorp.com

¿Tiene alguna consulta que deba ser respondida de inmediato? Llame por teléfono al servicio técnico de Cascade más cercano. Visítenos en www.cascorp.com

AMERICAS

**Cascade Corporation
U.S. Headquarters**
2201 NE 201st
Fairview, OR 97024-9718
Tel: 800-CASCADE (227-2233)
Fax: 888-329-8207

Cascade Canada Inc.
5570 Timberlea Blvd.
Mississauga, Ontario
Canada L4W-4M6
Tel: 905-629-7777
Fax: 905-629-7785

Cascade do Brasil
Rua João Guerra, 134
Macuco, Santos - SP
Brasil 11015-130
Tel: 55-13-2105-8800
Fax: 55-13-2105-8899

EUROPE-AFRICA

**Cascade Italia S.R.L.
European Headquarters**
Via Dell'Artigianato 1
37030 Vago di Lavagno (VR)
Italy
Tel: 39-045-8989111
Fax: 39-045-8989160

Cascade (Africa) Pty. Ltd.
PO Box 625, Isando 1600
60A Steel Road
Sparton, Kempton Park
South Africa
Tel: 27-11-975-9240
Fax: 27-11-394-1147

ASIA-PACIFIC

Cascade Japan Ltd.
2-23, 2-Chome,
Kukuchi Nishimachi
Amagasaki, Hyogo
Japan, 661-0978
Tel: 81-6-6420-9771
Fax: 81-6-6420-9777

Cascade Korea
121B 9L Namdong Ind.
Complex, 691-8 Gojan-Dong
Namdong-Ku
Inchon, Korea
Tel: +82-32-821-2051
Fax: +82-32-821-2055

Cascade-Xiamen
No. 668 Yangguang Rd.
Xinyang Industrial Zone
Haicang, Xiamen City
Fujian Province
P.R. China 361026
Tel: 86-592-651-2500
Fax: 86-592-651-2571

**Cascade India Material
Handling Private Limited**
No 34, Global Trade Centre
1/1 Rambaugh Colony
Lal Bahadur Shastri Road,
Navi Peth, Pune 411 030
(Maharashtra) India
Phone: +91 020 2432 5490
Fax: +91 020 2433 0881

Cascade Australia Pty. Ltd.
1445 Ipswich Road
Rocklea, QLD 4107
Australia
Tel: 1-800-227-223
Fax: +61 7 3373-7333

Cascade New Zealand
15 Ra Ora Drive
East Tamaki, Auckland
New Zealand
Tel: +64-9-273-9136
Fax: +64-9-273-9137

**Sunstream Industries
Pte. Ltd.**
18 Tuas South Street 5
Singapore 637796
Tel: +65-6795-7555
Fax: +65-6863-1368