

I **INSTALLATION INSTRUCTIONS**

E-Series ***Carton Clamp***

Manual Number 212116 R-1

cascade[®]
Cascade is a Registered Trademark of Cascade Corporation

C ONTENTS

Recommended Hydraulic Supply	<i>i</i>
Truck Requirements	1
Installation Procedures	2
Load Troubleshooting	8
Periodic Maintenance	10

This Manual provides instructions for installing a Cascade E-Series Carton Clamp. Follow the suggested installation procedures for best results. If you have any questions or need more information, contact your nearest Cascade Service Department (see back cover).

Read the **WARNING** Statements placed throughout this Manual to emphasize safety during Clamp installation.

IMPORTANT: Field alterations may impair performance or capability and could result in loss of warranty. Consult Cascade for any required modifications.

R ECOMMENDED HYDRAULIC SUPPLY OPTIONS

E-Series Carton Clamps can be operated with any of the hydraulic supply arrangements shown below. Refer to *Cascade Hose & Cable Reel Selection Guide*, Part No. 212199, to select the correct hose reel for the mast and truck. The hose and fitting requirements are:

- All hoses and fittings for clamp and sideshift functions should be at least No. 6 with 9/32 in. (7 mm) minimum I.D.

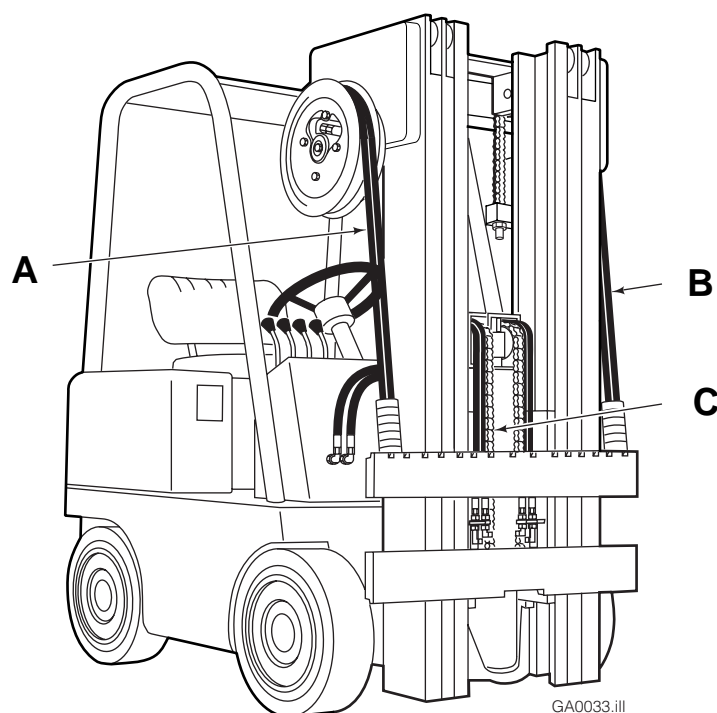

Non-Sideshifting

A or B

RH or LH THINLINE™ 2-port hose reel group.

OR

C Mast single internal hose reeving group.

Sideshifting

A and B

RH and LH THINLINE™ 2-port cable hose reel groups.

OR

C Mast double internal hose reeving group.

Sideshifting with Solenoid

A 6-N-1 cable/hose reel group

OR

A and C

Cable reel and single internal hose reeving group.

T RUCK REQUIREMENTS



WARNING: Rated capacity of the truck/attachment combination is a responsibility of the original truck manufacturer and may be less than that shown on the attachment nameplate. Consult the truck nameplate.

Truck Relief Setting

2300 psi (160 bar) Recommended
2600 psi (180 bar) Maximum

Truck Flow Volume ^①

	Min. ^②	Recommended	Max. ^③
20E, 30E, 40E, 45E	5 GPM (19 L/min.)	7.5 GPM (28 L/min.)	10 GPM (38 L/min.)

- ① Cascade E-Series Carton Clamps are compatible with SAE 10W petroleum base hydraulic fluid meeting Mil. Spec. MIL-0-5606 or MIL-0-2104B. Use of synthetic or aqueous base hydraulic fluid is not recommended. If fire resistant hydraulic fluid is required, special seals must be used. Contact Cascade.
- ② Flow less than recommended will result in reduced system performance.
- ③ Flow greater than maximum can result in excessive heating, reduced system performance and short hydraulic system life.

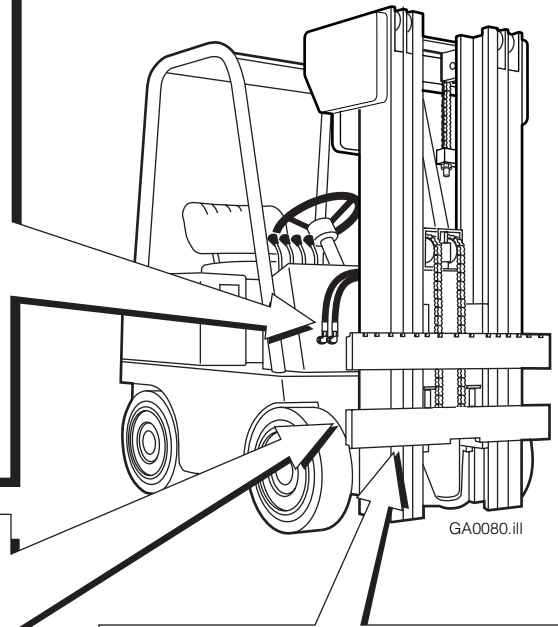

Carriage

Clean carriage bars and inspect for damaged notches



Carriage Mount Dimension (A) ITA (ISO)

	Minimum	Maximum
Class II	14.96 in. (380.0 mm)	15.00 in. (381.0 mm)
Class III	18.68 in. (474.5 mm)	18.74 in. (476.0 mm)

GA0028.iii

Auxiliary Valve Functions

Check for compliance with ANSI standards:

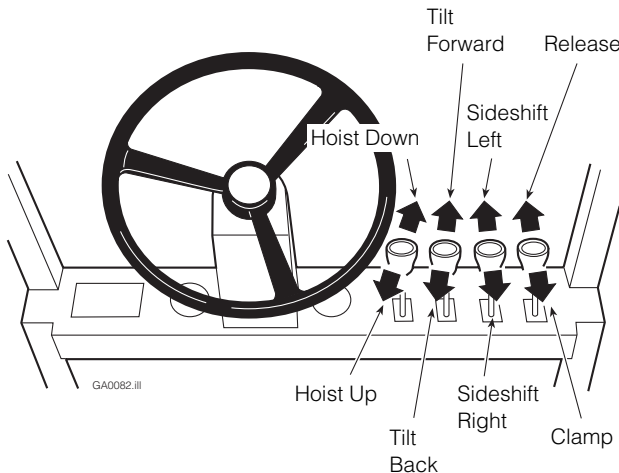

Follow the steps shown to install the Clamp on the truck. Read and understand all **WARNING** and **CAUTION** statements. If you don't understand a procedure, ask your supervisor, or call the nearest Cascade Service Department for assistance.

1 Prepare Attachment

- A** Remove banding.
- B** Remove bolt-on lower mounting hooks (if equipped).

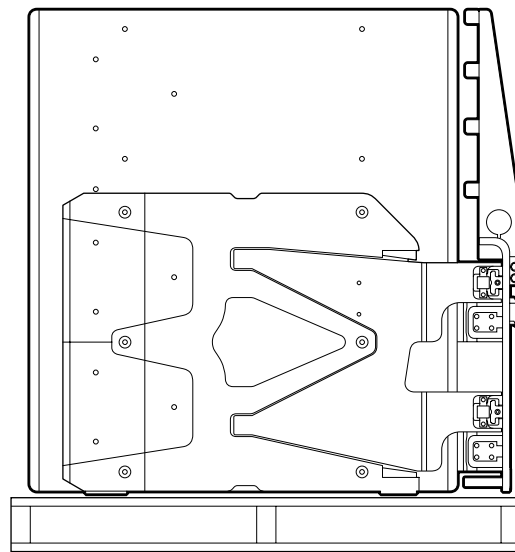

CL0244.ill

B Bolt-On Lower Hooks

2 Unlock quick-change lower mounting hooks

- A** Remove pin and drop hooks into unlocked position.
- B** Reinstall pin in lower hole.

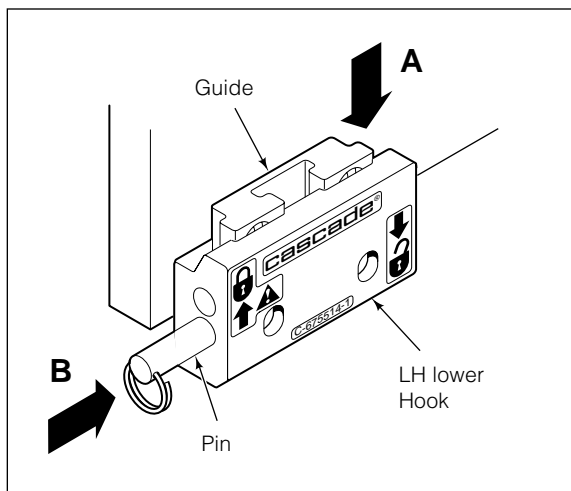

NOTE: Guides can be reversed to reduce hook-to-carriage clearance (See lower hook installation, Step 6).

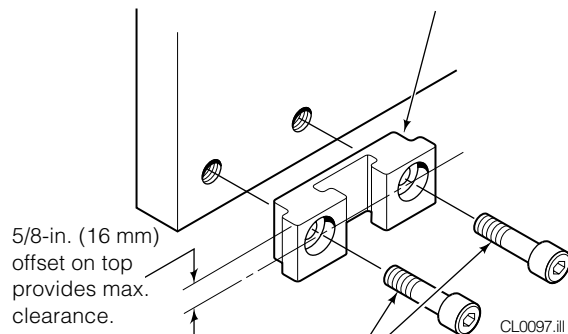

3 Prepare Hoses

- A** Determine hose lengths required for hydraulic supply configuration of truck.
- B** Cut hoses to length, install end fittings.

IMPORTANT: Attachment hydraulic lines can be plumbed to either side of the dual-ported main valve if required, to match existing truck supply configurations.

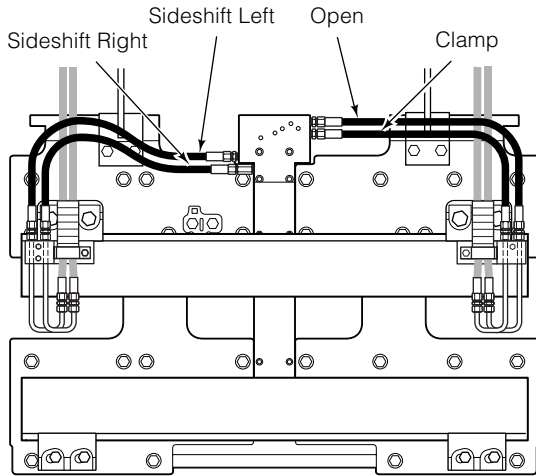

Sideshifting – Double Hose Reels

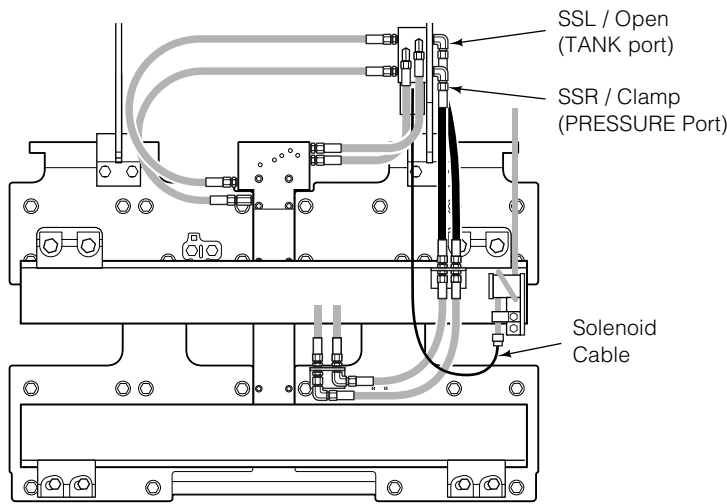

Sideshifting with Solenoid – IHR and Cable Reel

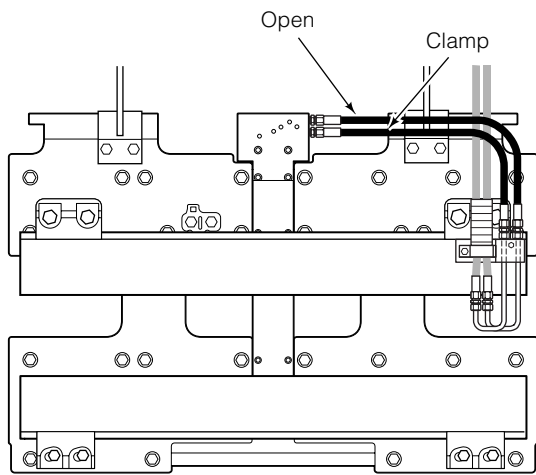

Non-Sideshifting – Single Hose Reel

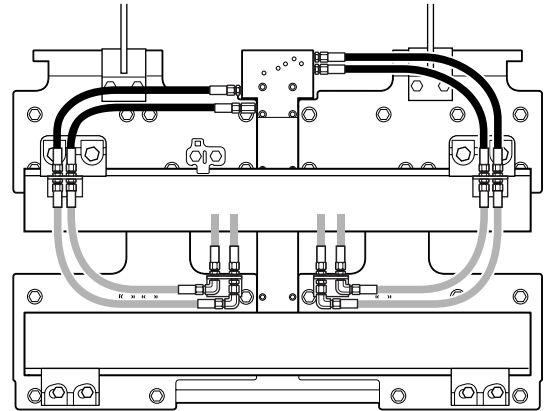

Sideshifting – Double Internal Hose Reeving

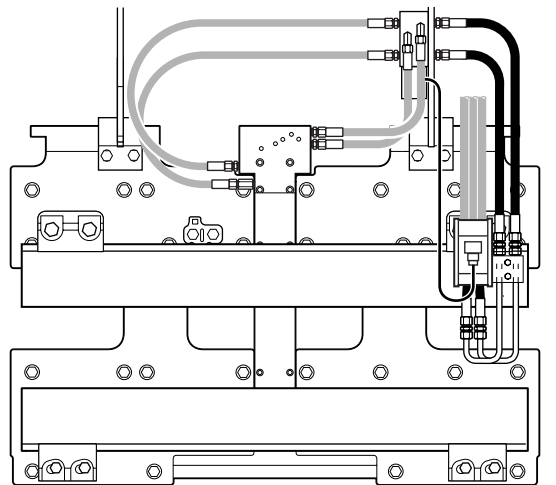

Sideshifting with Solenoid – 6-N-1 Cable/Hose Reel

4 Flush hydraulic supply hoses

- A** Install hoses using union fittings.
- B** Operate auxiliary valves for 30 sec.
- C** Remove union fittings.

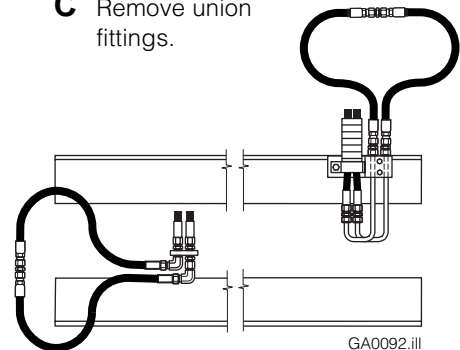

5 Mount Clamp on truck carriage

- A** Center truck behind Clamp.
- B** Tilt forward and raise carriage into position.
- C** Engage top mounting hooks with carriage. Make sure centering tab engages a notch on the top carriage bar. **NOTE:** Centering tab can be oriented in 4 different positions to center the Clamp (see illustration).
- D** Lift Clamp 2 in. (5 cm) off pallet.

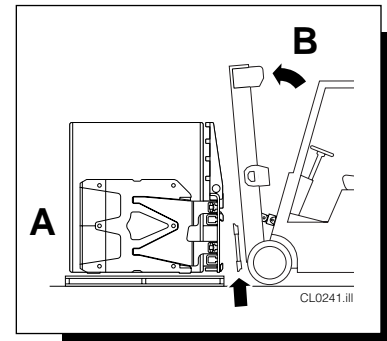

ITA Class II – 0.60–0.66 in. (15–17 mm)
 ITA Class III – 0.72–0.78 in. (18–20 mm)

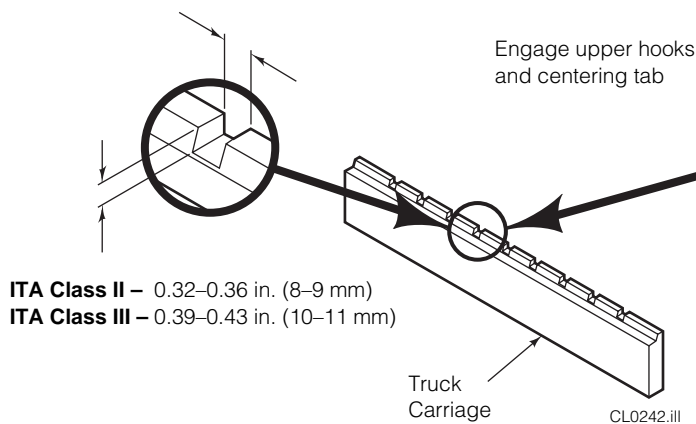

ITA Class II – 0.32–0.36 in. (8–9 mm)
 ITA Class III – 0.39–0.43 in. (10–11 mm)

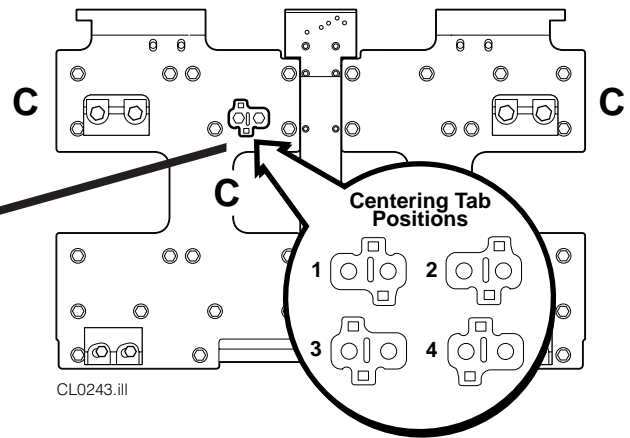

6 Install and engage lower hooks

QUICK-CHANGE TYPE

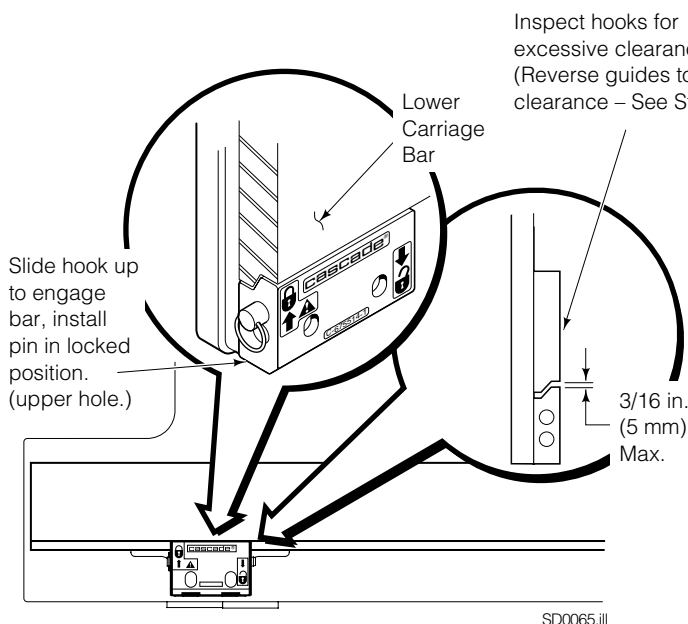

Inspect hooks for excessive clearance. (Reverse guides to reduce clearance – See Step 2.)

BOLT-ON TYPE

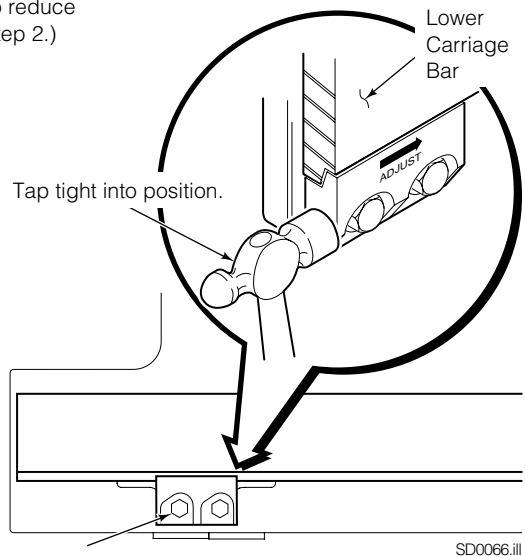

Tighten Capscrews:
Class II / III Mounting – 165 ft.-lbs. (225 Nm)

7 Connect hoses prepared in Step 3 to Attachment

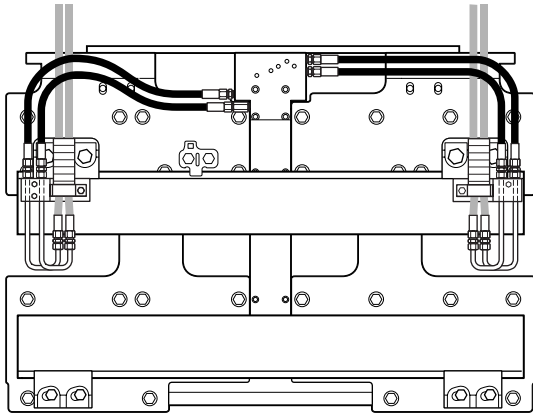

CL0593.iii

Double Hose Reels Hydraulic Supply

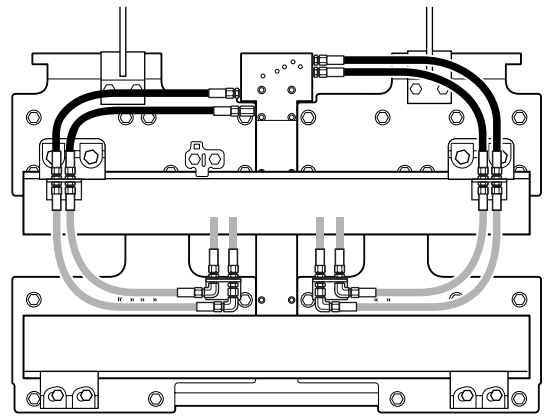

CL0588.iii

Internal Hose Reeving Hydraulic Supply

8 Install solenoid control knob – (solenoid-equipped units)

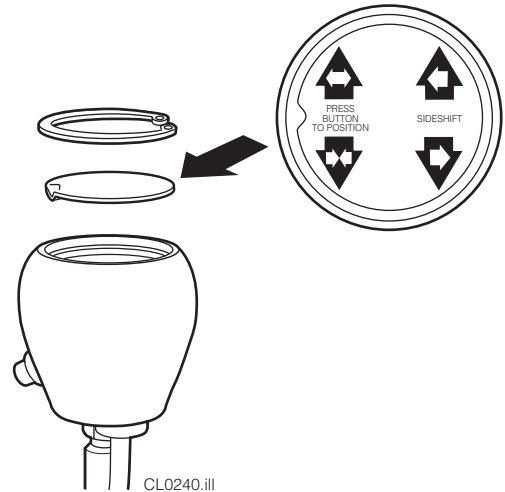
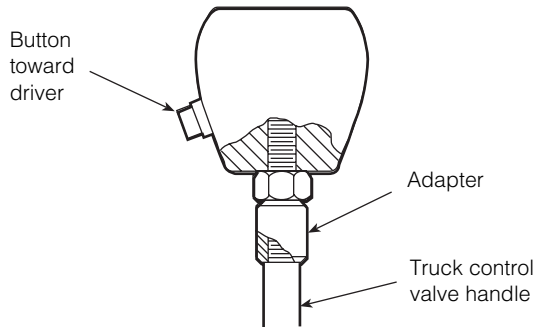

9 Install wiring – (Solenoid equipped units)

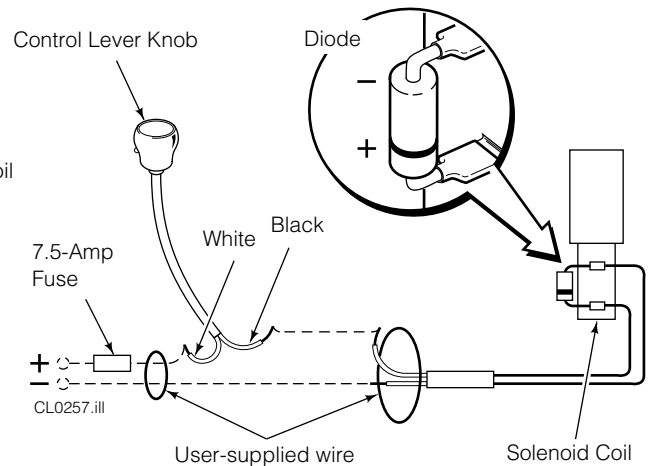
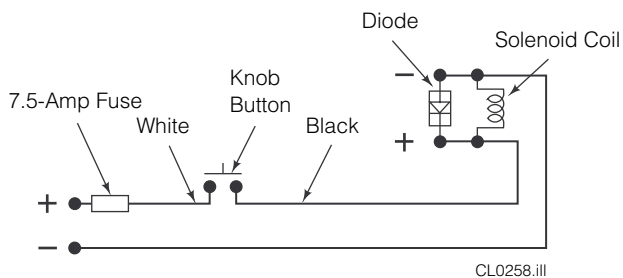

10 Cycle Clamp functions

- With no load, cycle each Clamp function several times.
- Check for operation in accordance with ITA (ISO) standards.
- Clamp and lift a maximum load. Sideshift left and right. Check for proper clamp force, equal arm movement and adequate speed. If necessary, adjust relief valve cartridges (see Step 11).
- Check for leaks at fittings, valve, manifold and cylinders.



WARNING: Make sure all personnel are clear of the Clamp during testing.

NON-SIDESHIFTING CLAMPS

- A** Release Arms
- B** Clamp Arms
- C** (not used)
- D** (not used)

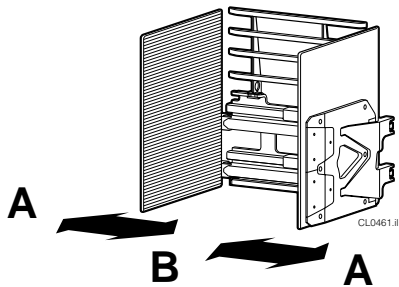

SIDESHIFTING CLAMPS

- A** Sideshift Left
- B** Sideshift Right
- C** Release Arms
- D** Clamp Arms

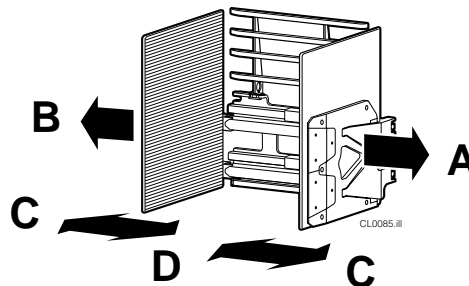

SIDESHIFTING CLAMPS WITH SOLENOID VALVE

- A** Sideshift Left
- A** Release Arms (press knob button)
- B** Sideshift Right
- B** Clamp Arms (press knob button)

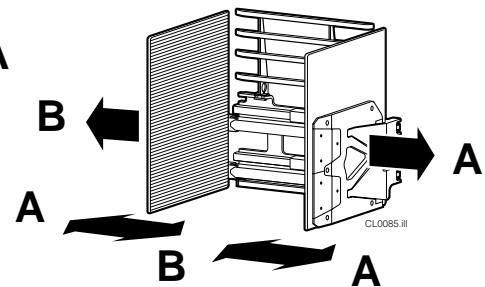

AUXILIARY VALVE FUNCTIONS

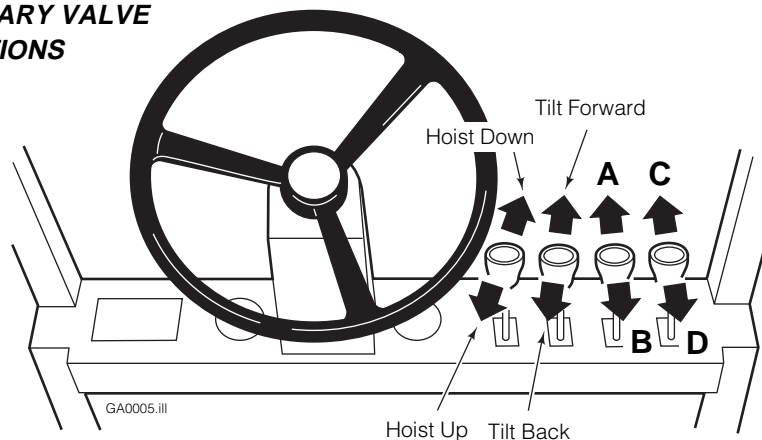

11 Adjust relief cartridges

For over-pressure protection, the relief valve cartridges for both the CLAMP and SIDE-SHIFT functions should be adjusted to match the truck hydraulic flow rate.



WARNING: Before removing hydraulic lines or components, relieve pressure in the hydraulic system. Turn the truck off and open the truck auxiliary control valves several times in both directions.

Clamp relief adjustment:

- A** Confirm that the truck pressure is between 2300–2600 psi (160–180 bar) at the carriage hose terminal.
- B** Install a 3000-psi (200 bar) pressure gauge on the test port of the main valve. (No. 4 O-ring fitting required).
- C** Cycle arms to full open. Slowly close arms while clamping a maximum rigid load (or clamp force indicator). Hold the lever in the CLAMP position and accelerate the engine to develop full pressure.
- D** Adjust the **CLAMP** relief cartridge for an indicated 2300 psi (160 bar). Turn clockwise to increase pressure, counterclockwise to decrease. Tighten jam nut and replace cap.

Sideshift relief adjustment:

- E** With a maximum load clamped, sideshift full left and full right while checking for an arm speed of 8–10 in./sec.
- F** Using an Allen wrench, adjust the **SIDESHIFT** relief cartridge counterclockwise (CCW) 1/4-turn. Repeat Steps E and F until sideshift speed slows (relief opening).
- G** Readjust cartridge clockwise (CW) 1/4-turn. Tighten jam nut and replace cap.

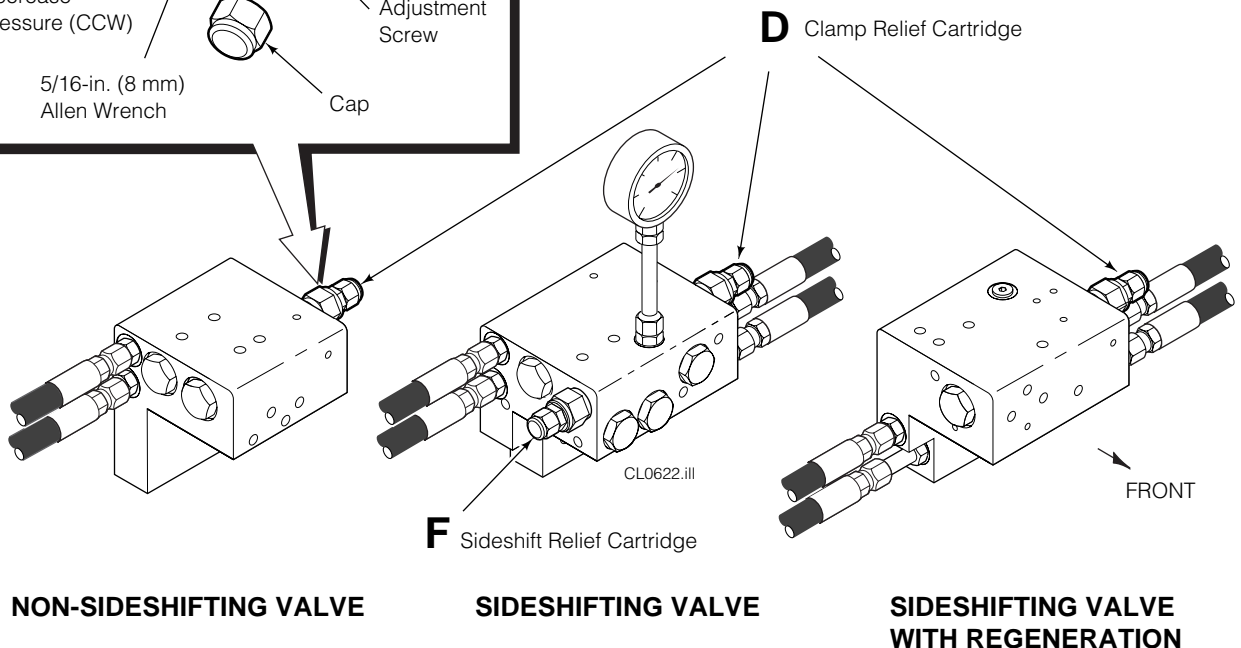
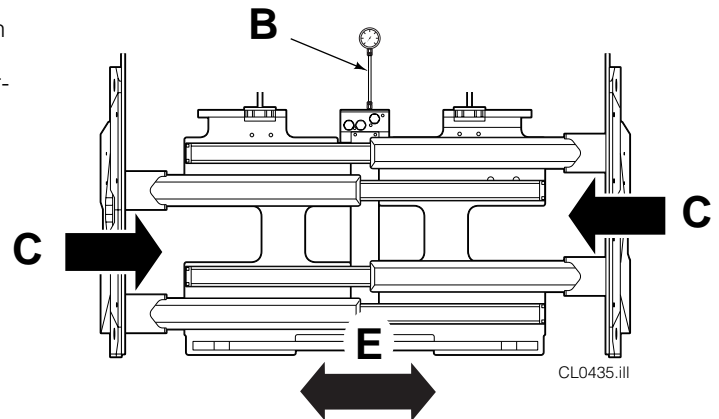
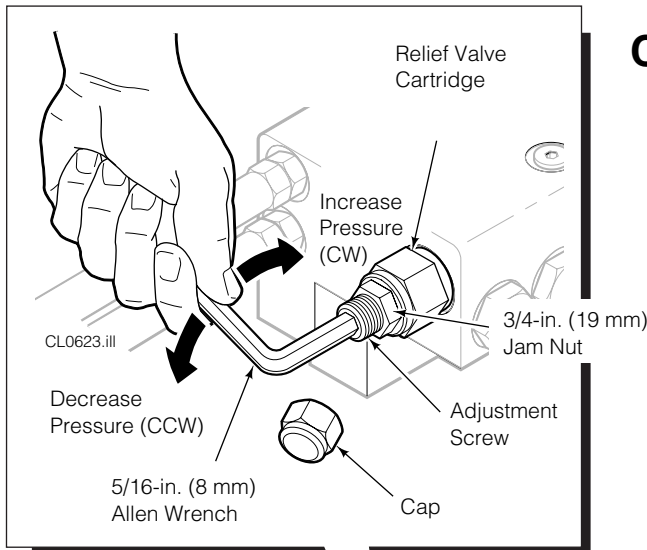

LOAD TROUBLESHOOTING

IF FRONT STACK OF LOAD TILTS OUT:

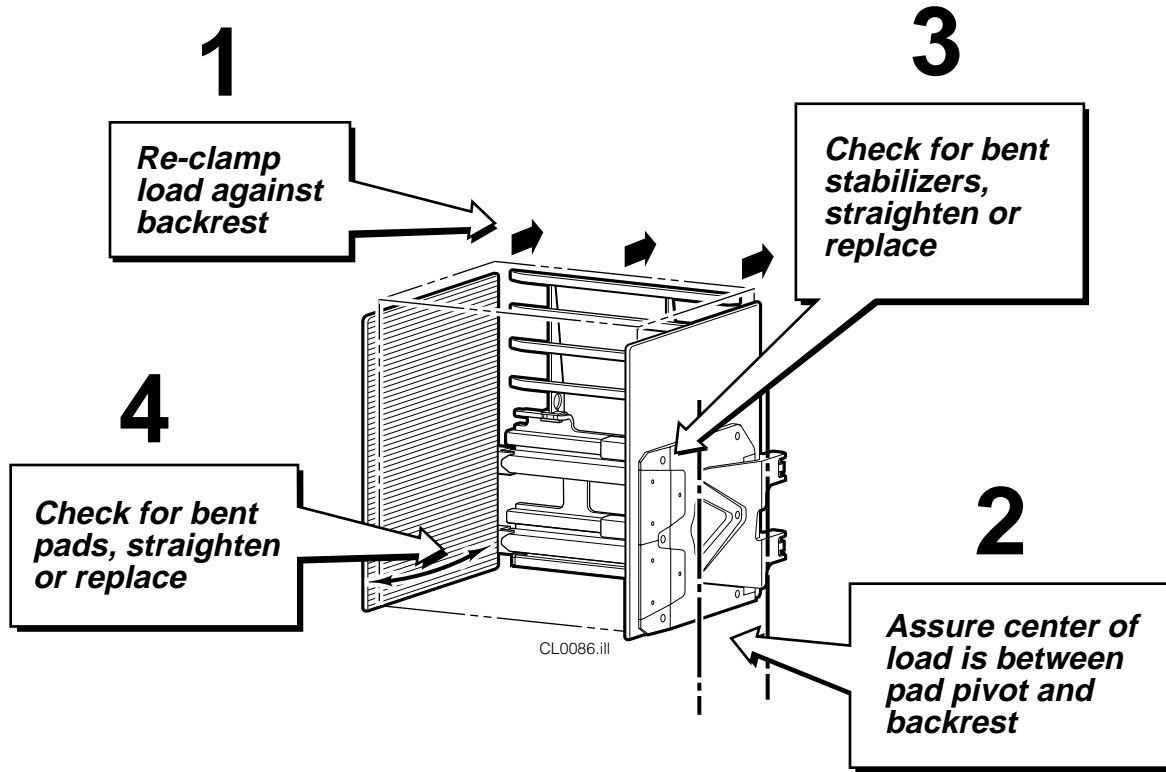

IF LOWER TIER OF LOAD BRIDGES DOWN OR SLIDES OUT:

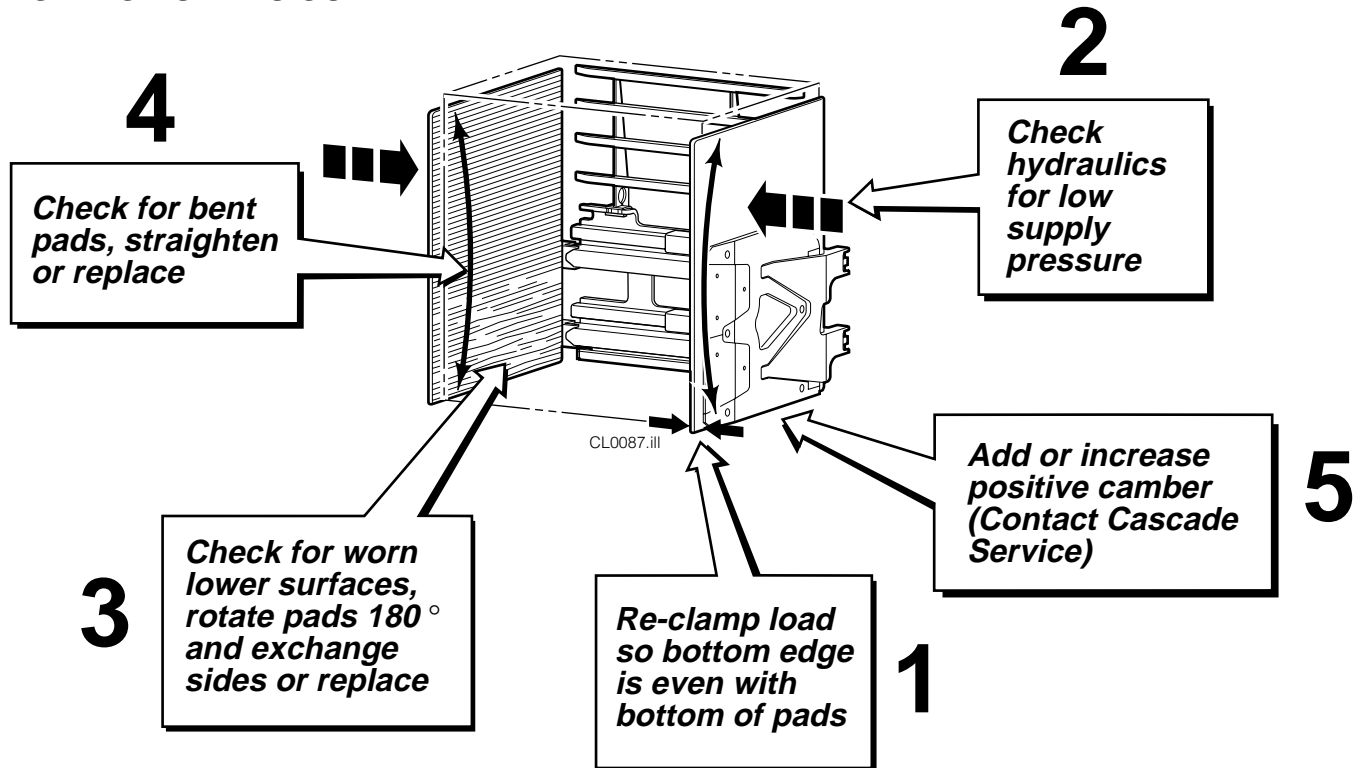

LOAD TROUBLESHOOTING

IF LOWER TIER OF LOAD IS CREASED:

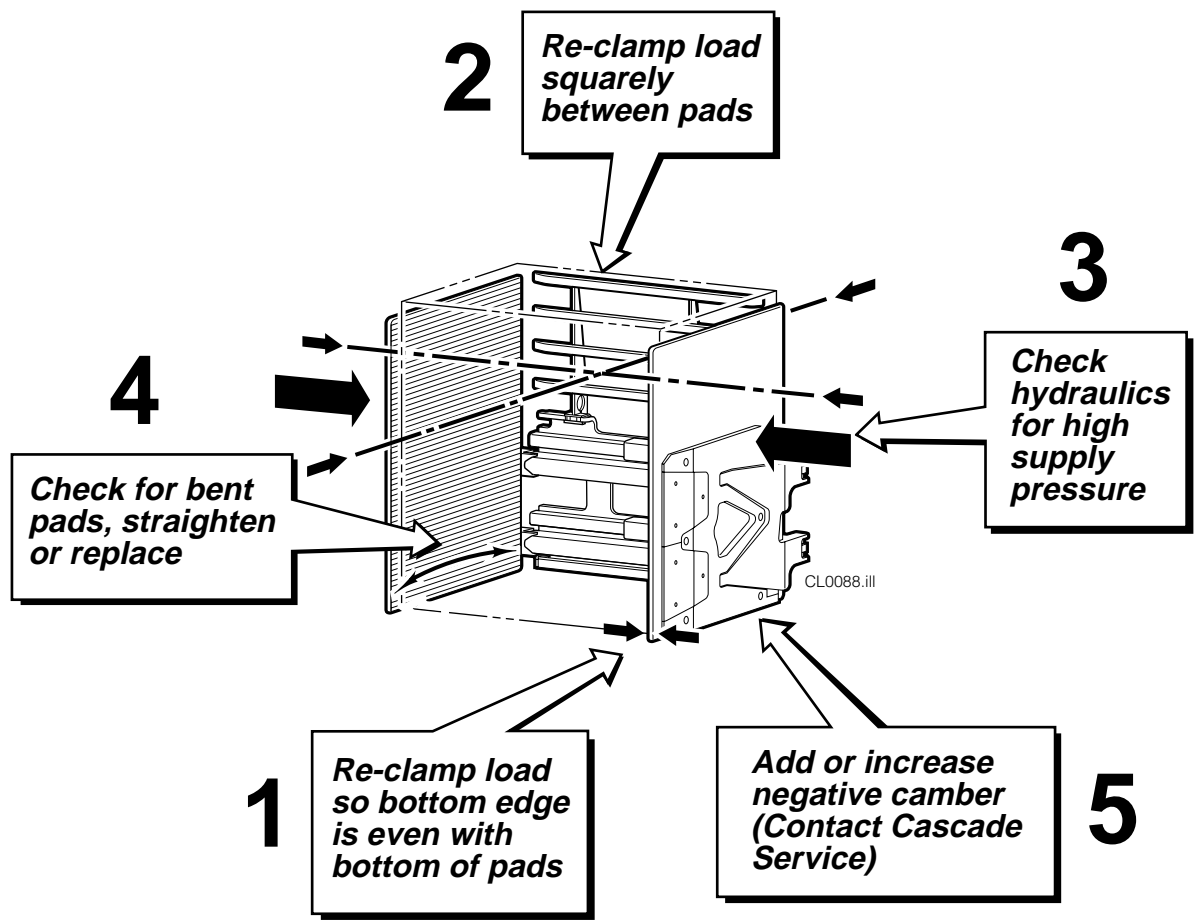



WARNING: After completing any service procedure, always test the Clamp through five complete cycles. First test empty, then test with a load to make sure the Clamp operates correctly before returning it to the job.

IMPORTANT: E-Series Clamps are prelubed at the factory. Lubrication is not necessary for installation.

100-Hour Maintenance

Every time the lift truck is serviced or every 100 hours of truck operation, whichever comes first, complete the following maintenance procedures on the Clamp:

- Check for loose or missing bolts, worn or damaged supply hoses and hydraulic leaks.
- Inspect the cylinder rod anchors for wear or damage. The rod anchors operate with a loose clearance and require no lubrication.
- Check for equal movement of the arms.
- Check safety decals and nameplate for legibility.

500-Hour Maintenance

After each 500 hours of truck operation, in addition to the 100-hour maintenance, perform the following procedures:

- Inspect the arm bearing surfaces for wear or damage. If lubrication is required, silicon spray or light grease is recommended.
- Check the clearance between the lower mounting hooks and the truck carriage bar:

Quick-Change Hooks – 3/16 in. (5 mm) max.

Bolt-on Hooks – Tight against lower carriage bar.

If adjustment is necessary, refer to Installation Step 6. Tighten lower hook capscrews to 165 ft.-lbs. (225 Nm).

1000-Hour Maintenance

After each 1000 hours of truck operation, in addition to the 100 and 500-hour maintenance, perform the following procedures:

- Tighten baseplate capscrews (see Table).
- Tighten cylinder rod anchor capscrews (see Table)
- Tighten contact pad mounting bolts to 50 ft.-lbs. (65 Nm).

Model	Torque Values	
	Baseplate	Cyl. Rod Anchor
20E	75 ft.-lbs. – M12 (100 Nm)	30 ft.-lbs. (40 Nm)
30E	75 ft.-lbs. – M12 (100 Nm) 195 ft.-lbs. – M16 (265 Nm)	30 ft.-lbs. (40 Nm)
40E, 45E	195 ft.-lbs. – M16 (265 Nm)	50 ft.-lbs. (65 Nm)

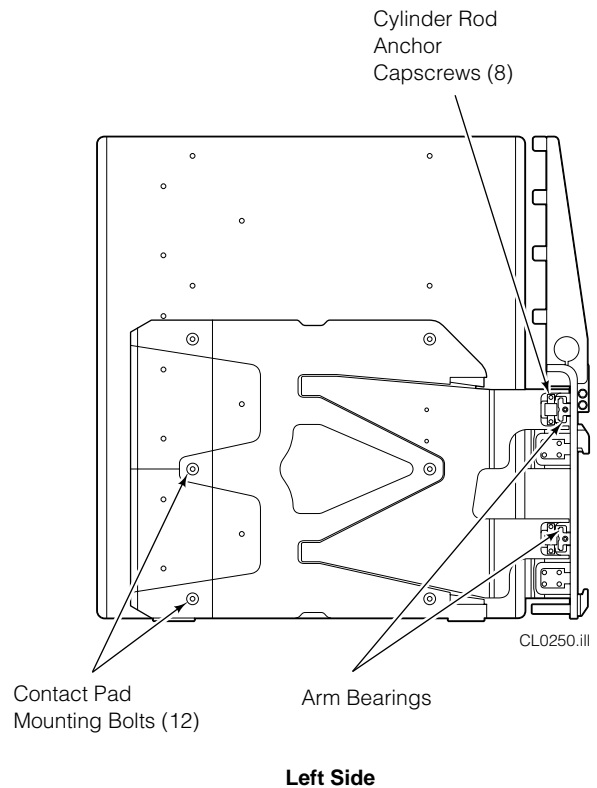
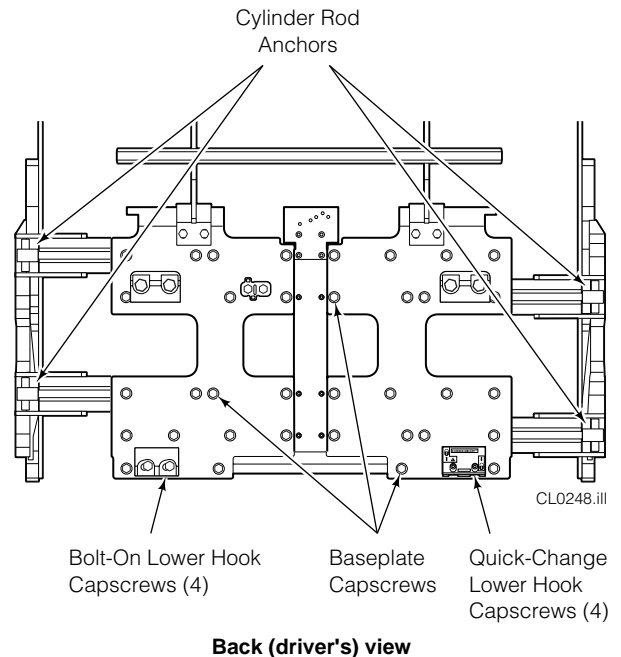

Do you have questions you need answered right now?

Call your nearest Cascade Service Department.
Visit us online at www.cascorp.com

AMERICAS

**Cascade Corporation
U.S. Headquarters**
2201 NE 201st
Fairview, OR 97024-9718
Tel: 800-CASCADE (227-2233)
Fax: 888-329-8207

Cascade Canada Inc.
5570 Timberlea Blvd.
Mississauga, Ontario
Canada L4W-4M6
Tel: 905-629-7777
Fax: 905-629-7785

Cascade do Brasil
Rua João Guerra, 134
Macuco, Santos - SP
Brasil 11015-130
Tel: 55-13-2105-8800
Fax: 55-13-2105-8899

EUROPE-AFRICA

**Cascade Italia S.R.L.
European Headquarters**
Via Dell'Artigianato 1
37050 Vago di Lavagno (VR)
Italy
Tel: 39-045-8989111
Fax: 39-045-8989160

Cascade (Africa) Pty. Ltd.
PO Box 625, Isando 1600
60A Steel Road
Sparton, Kempton Park
South Africa
Tel: 27-11-975-9240
Fax: 27-11-394-1147

ASIA-PACIFIC

Cascade Japan Ltd.
2-23, 2-Chome,
Kukuchi Nishimachi
Amagasaki, Hyogo
Japan, 661-0978
Tel: 81-6-6420-9771
Fax: 81-6-6420-9777

Cascade Korea
121B 9L Namdong Ind.
Complex, 691-8 Gojan-Dong
Namdong-Ku
Inchon, Korea
Tel: +82-32-821-2051
Fax: +82-32-821-2055

Cascade-Xiamen
No. 668 Yangguang Rd.
Xinyang Industrial Zone
Haicang, Xiamen City
Fujian Province
P.R. China 361026
Tel: 86-592-651-2500
Fax: 86-592-651-2571

**Cascade India Material
Handling Private Limited**
No 34, Global Trade Centre
1/1 Rambaugh Colony
Lal Bahadur Shastri Road,
Navi Peth, Pune 411 030
(Maharashtra) India
Phone: +91 020 2432 5490
Fax: +91 020 2433 0881

Cascade Australia Pty. Ltd.
1445 Ipswich Road
Rocklea, QLD 4107
Australia
Tel: 1-800-227-223
Fax: +61 7 3373-7333

Cascade New Zealand
15 Ra Ora Drive
East Tamaki, Auckland
New Zealand
Tel: +64-9-273-9136
Fax: +64-9-273-9137

**Sunstream Industries
Pte. Ltd.**
18 Tuas South Street 5
Singapore 637796
Tel: +65-6795-7555
Fax: +65-6863-1368

