



Technical Bulletin

D-Series Carton Clamp Check Valve Spool Adjustment

Models: 20D, 35D, and 60D Carton Clamps

Problem: Carton Clamps mounted on trucks supplying less than 8 GPM oil volume to the attachment may experience unequal arm movement due to the low flow volume of oil.

Solution: Move the bushings on the spool assembly as instructed below.

1. Check the oil flow volume to the attachment using Cascade Flow Meter Kit 671476 or a similar 1-10 GPM inline flow meter.

- If the flow is 8 GPM or less, continue as follows.

2. Remove the plug and spool assembly.

3. Move both bushings to the inboard position as shown.

4. Install the spool assembly and plug. Tighten the plug to a torque of 10-12 ft.-lbs.

NOTE: This procedure may not work for flow volumes below 4 GPM. If so, call your nearest Cascade Service Representative.

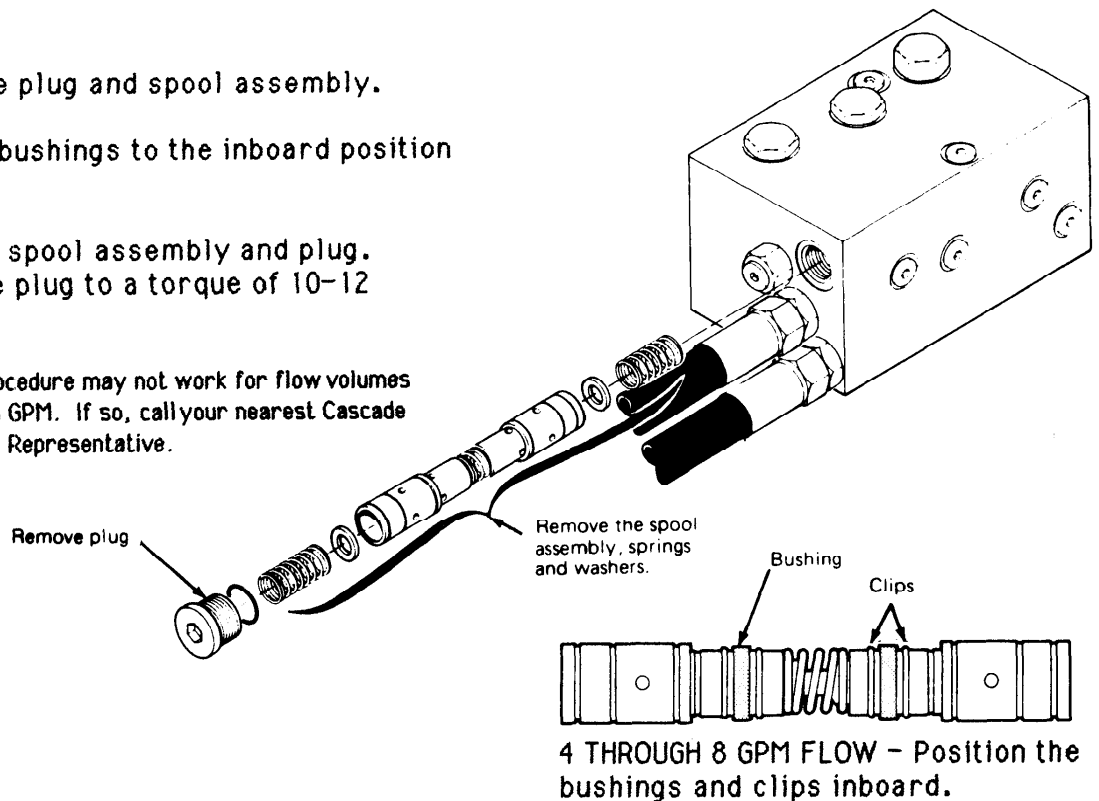

NOTE: This information should not be interpreted as the basis for warranty claims unless so designated.

Part No. 676638

CASCADE CORPORATION

For Technical Assistance...

Call: 1-800-CASCADE (272-6223) ext. 100

OR

Write: Cascade Corporation, 10000 E. 10th, Farmington, UT 84201

To Order Parts...

Call: 613-322-1199

OR

Write: Cascade Corporation, P.O. Box 360 Springfield, OH 45505