



# Technical Bulletin

Number 110  
February, 1979

LOAD PUSH/PULL SEQUENCE VALVE SERVICE KIT C-666645 for VALVES C-629417, C-653502 and C-661133

Push/Pull Models P5 and P7 shipped prior to January 1, 1979

**PROBLEM:** The pusher plate starts to retract before the gripper jaw clamps the slip sheet lip. This occurs when the 1-1/2" spring (C-630185), inside the sequence valve, breaks or takes a permanent set.

**SOLUTION:** Replace the broken spring, end cap with O-ring, and stop with the 2-1/2" spring, end cap with O-ring, and stop, contained in Service Kit C-666645 shown below.

The Service Kit C-666645 can be ordered by contacting:

Cascade Corporation  
Parts Depot  
P.O. Box 360  
Springfield, Ohio 45505  
Telephone: (513) 325-9271  
Telex: 205413

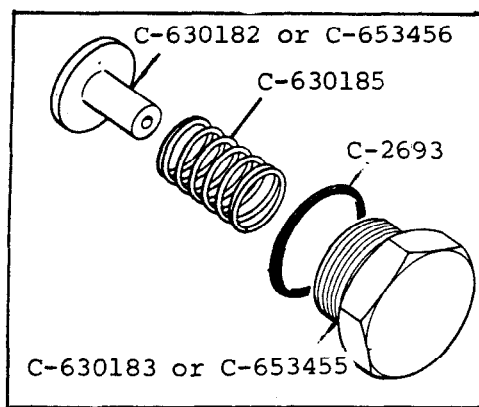

OLD

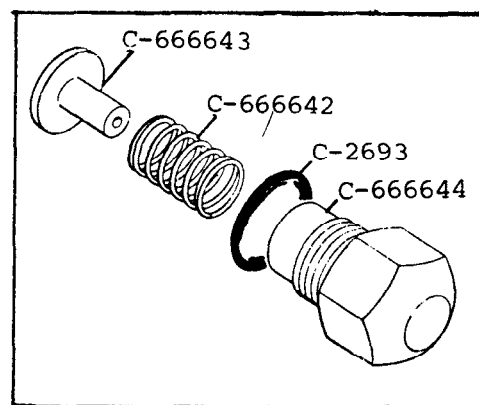

NEW

Service Kit C-666645

## **cascade<sup>®</sup> corporation**

For Technical Assistance . . .

Call/ 1-800-CASCADE or 503-669-6300

OR

Write: Cascade Corporation, P.O. Box 20187, Portland, OR 97220

To Order Parts . . .

Call: 513-322-1199

OR

Write: Cascade Corporation, P.O. Box 360, Springfield, OH 45505