

# Operator's Guide

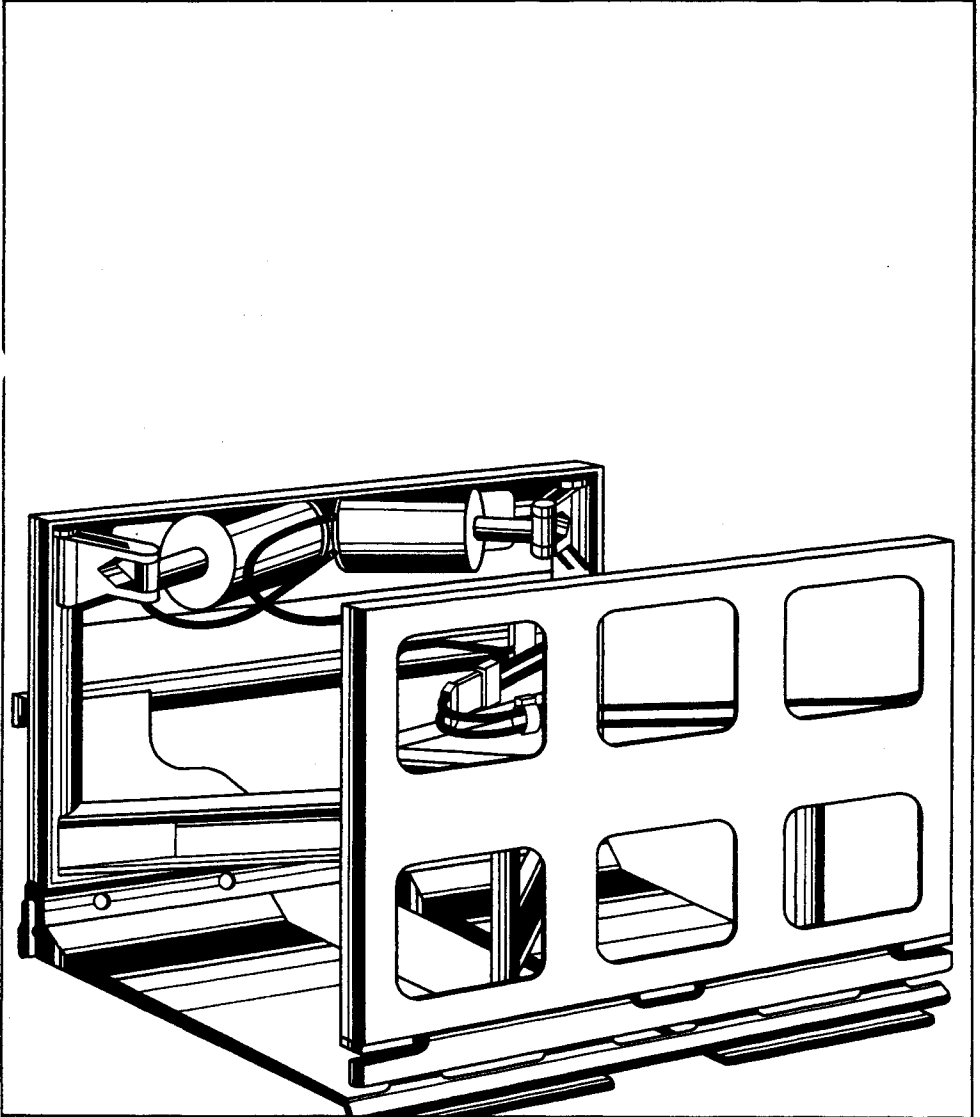

**Load Push and  
Load Push/Pull**



**cascade  
corporation**

# Models

Load Push and Load Push/Pull attachments are designed to handle unit loads placed on slip sheets (also called "palletless handling" or "unitized load handling"). The top tapered platens allow a lower angle of entry. This lessens the danger of creasing cartons as they are pulled onto the platens. Optional sideshifting models provide easier load placement with less truck maneuvering. Other optional features, covered in this operator's guide, include the Multiple Stop Group, Sheet Sav®, Hydraulic Adjustable Platens, and Tilting Pusher Plate.

## Load Push L5, L7

The Load Push is used mainly for unloading (into warehouse storage) or loading for shipment (into a boxcar or van). The pusher plate provides a forward pushing action to the load so that it moves off the platens onto the floor or a pallet, or onto another load.

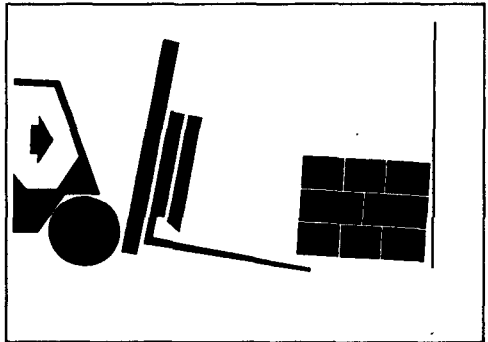

## Load Push/Pull P5, P7

The Load Push/Pull has the ability to pull loaded slip sheets onto the platens by means of an automatic gripper bar located at the bottom edge of the pusher plate. The gripper bar closes over the protruding lip of the slip sheet, pulling the load onto the platens when the pusher plate is retracted.

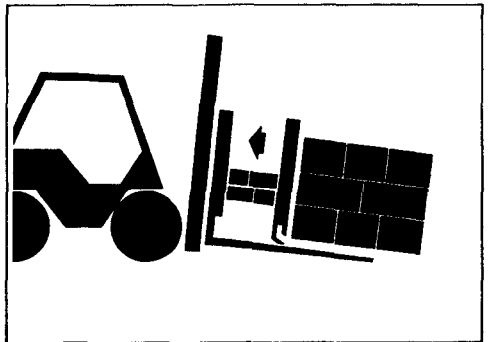

### WARNING



Rated capacity of the truck/attachment combination is a responsibility of the original truck manufacturer and may be less than shown on the attachment nameplate. Consult the truck nameplate.

# Contents

Introduction . . . . .	3
Operating Instructions—Load Push	
Pickup . . . . .	4
Discharge . . . . .	6
Operating Instructions—Load Push/Pull	
Pickup from the Floor . . . . .	8
Pickup from a Stack . . . . .	11
Discharge . . . . .	14
Operator Techniques . . . . .	16
Pickup . . . . .	16
Carrying A Load . . . . .	16
“Milking” . . . . .	17
Misaligned Pusher Plate . . . . .	17
Operator Safety Rules . . . . .	18
Optional Features	
Multiple Stop Group . . . . .	19
Sheet Sav® . . . . .	20
Hydraulic Adjustable Platens . . . . .	21
Tilting Pusher Plate . . . . .	22
Daily Inspection . . . . .	23

# Introduction

The purpose of this guide is to help you become more proficient in the operation of the Load Push and Load Push/Pull, and to help avoid common errors which often cause damage to the equipment or the load being carried.

Read this booklet thoroughly *BEFORE* attempting to operate the attachment. If you have any questions or don't understand a procedure described in this guide, ask your supervisor.

The illustration shows the components referred to in this operator's guide.

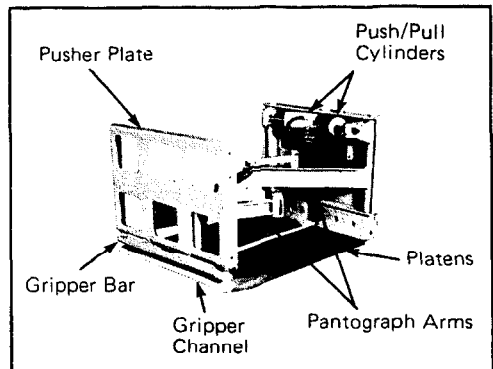

# Load Push Operating Instructions

## Pickup from the Floor

**1** Line up the platens squarely with the load.

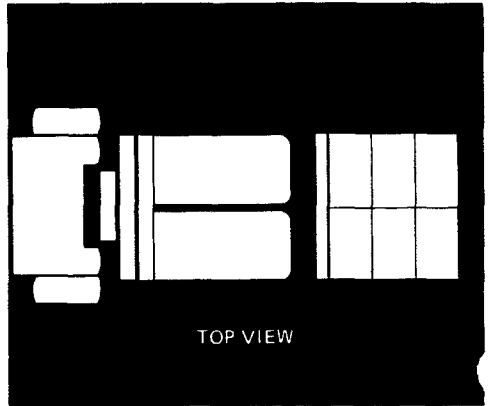

**2** Raise the platens about 3" above the floor.

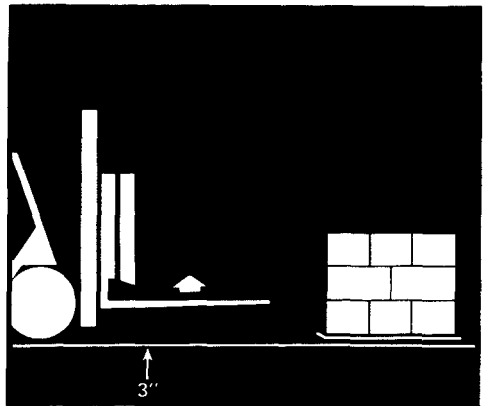

**3** Tilt the mast forward until the tips of the platens touch the floor.

*DO NOT* try to pick up a load with the platens flat on the floor. Doing so may rip the slip sheet and/or gouge the bottom layer of cartons.

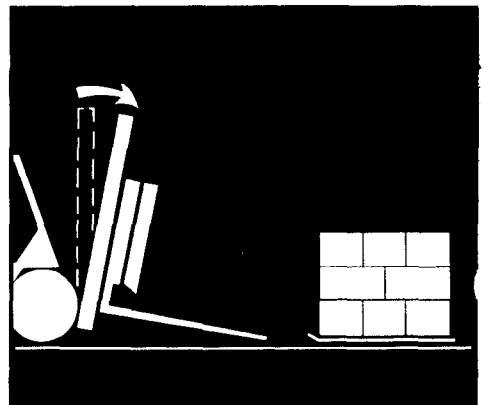

## Load Push

**4** Drive the truck forward until the platen tips are under the slip sheet, and continue to inch the platens under the load.

*CAUTION:* If the wheels of the truck start spinning, or the truck will not move forward once the platens are under the load, then you have entered at too sharp an angle, and the platens are wedging or digging into the floor. Back off and try again after making the necessary correction in platen angle.

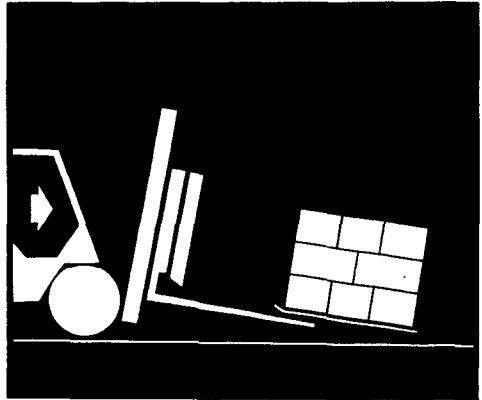

**5** As the platens slide under the load, straighten the mast and at the same time lower the carriage. When the load is completely on the platens, the mast should be vertical and the platens flat on the floor.

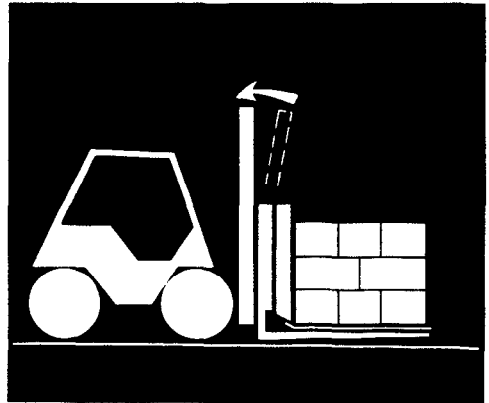

**6** Tilt the mast back, and elevate the platens 3"–4". You are now ready to transport the load.

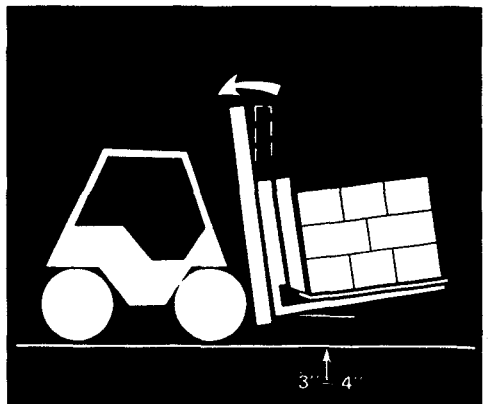

# Load Push Discharge

**1** Carefully position the load exactly above where it is to be discharged.

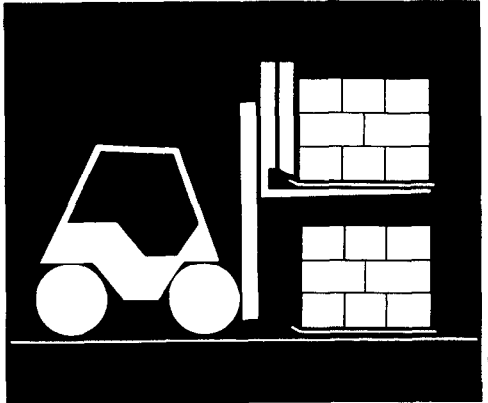

**2** Tilt the mast forward 3° to 4°.

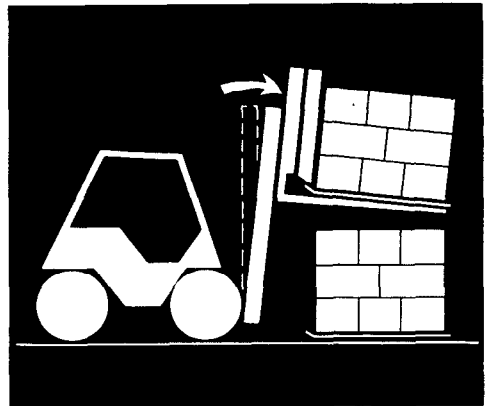

**3** Lower the carriage until the platen tips are about 1" above the discharging area.

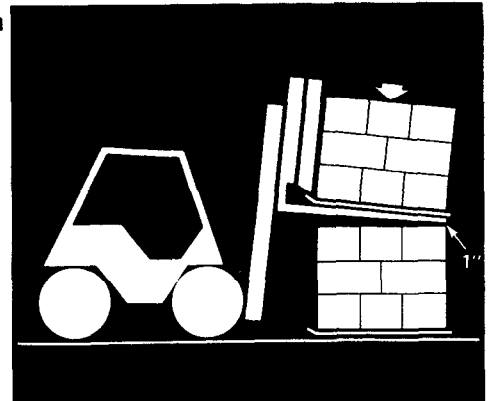

## Load Push

**4** Place the truck's transmission in neutral and start the pushing operation. As the pusher plate moves the load off, the truck will move backwards (with light loads, drive backwards slowly). As the weight is withdrawn from the platens they will deflect upward slightly. Compensate for this by lowering the carriage slightly.

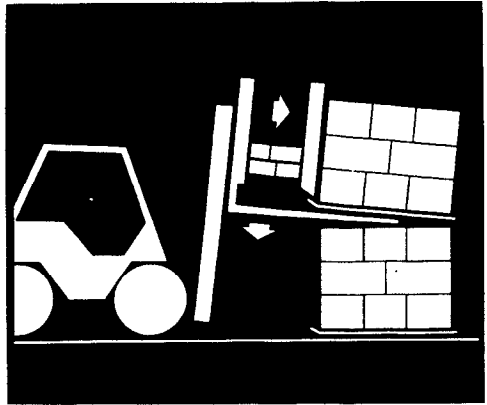

*NOTE:* If your truck does not operate in neutral, place the transmission in reverse and drive backwards slowly to coordinate the pushing motion with the reverse movement.

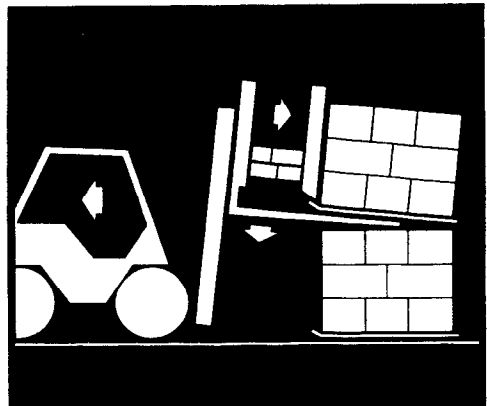

**5** Back away, tilt the mast back and raise or lower the platens to 3"–4" above the floor for traveling.

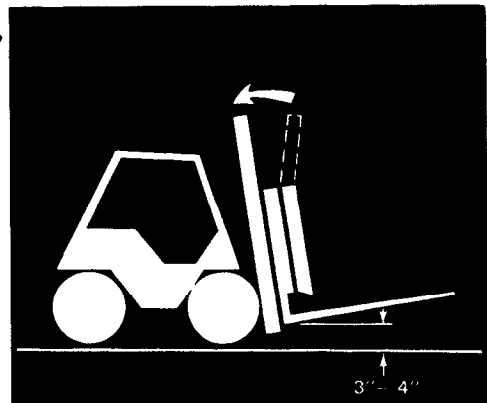

# Load Push/Pull Operating Instructions

## Pickup from the Floor

**1** Line up the platens squarely with the load.

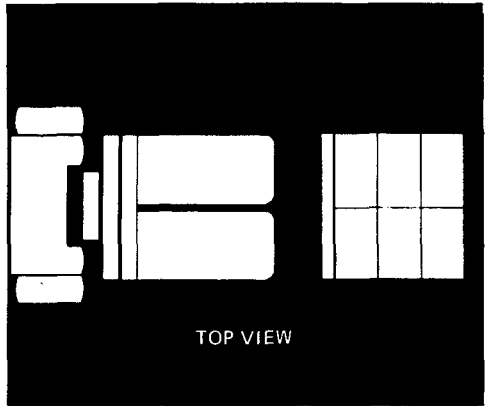

**2** Raise the platens about 3" above the floor.

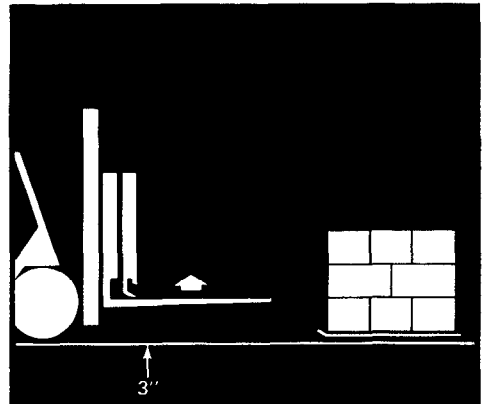

**3** Tilt the mast forward until the tips of the platens touch the floor.

*DO NOT* try to pick up a load with the platens flat on the floor. Doing so may rip the slip sheet and/or gouge the bottom layer of cartons.

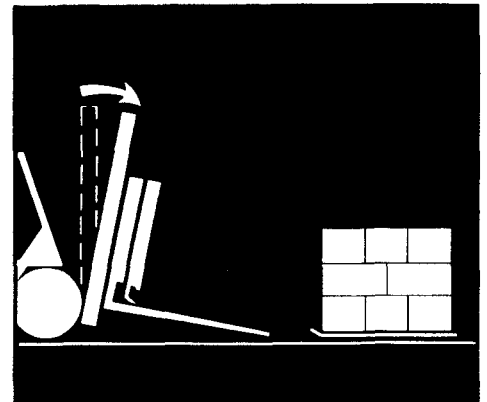

## Load Push/Pull

**4** Drive the truck forward until the platen tips are under the slip sheet lip.

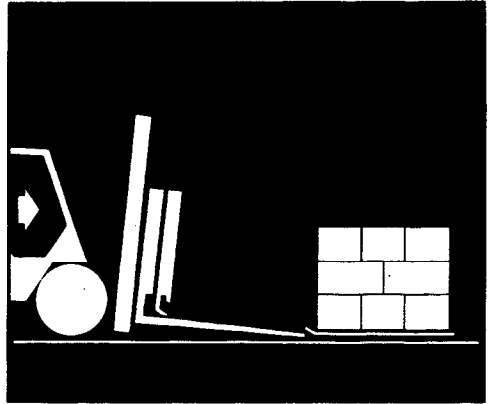

**5** Extend the pusher plate so that the slip sheet lip fits into the gripper channel opening.

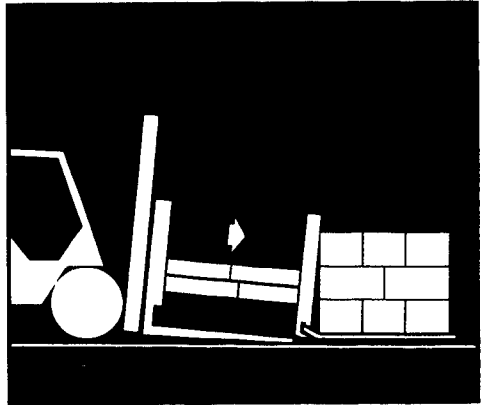

**6** Retract the pusher plate. The gripper bar will automatically clamp the slip sheet lip.

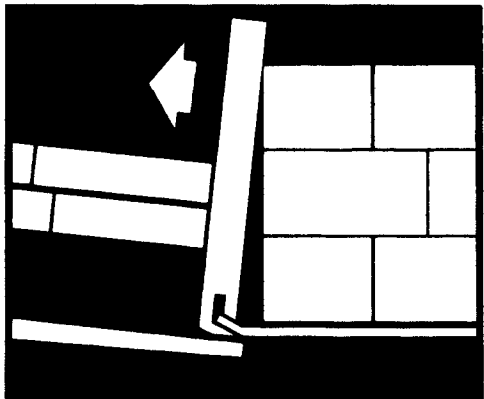

## Load Push/Pull Pickup from the Floor

**7** Move forward slowly as the load is being pulled onto the platens.

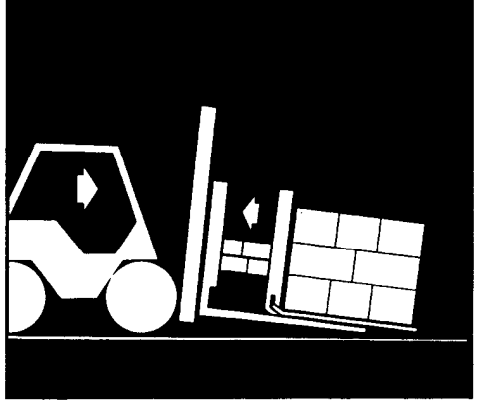

**8** As the weight of the load is transferred to the platens, they will deflect downward slightly. Raise the carriage about 1" to prevent the platen from digging into the floor. Slowly tilt the mast to a vertical position as you scoop up the load.

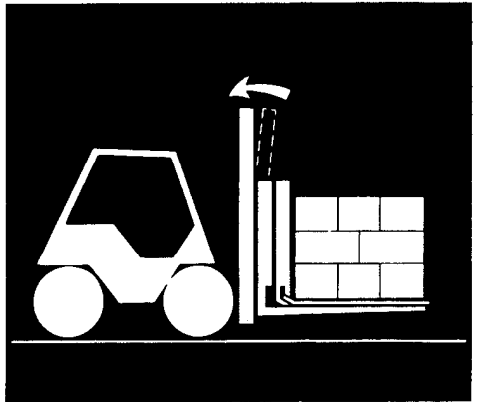

**9** Tilt the mast back, and raise the load 3"—4" above the floor. You are now ready to transport the load.

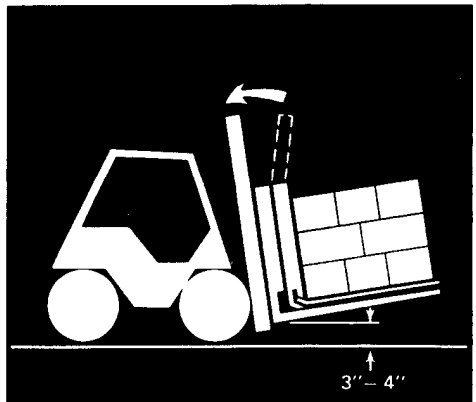

# Load Push/Pull Pickup from a Stack

**1** Line up the platens squarely with the load.

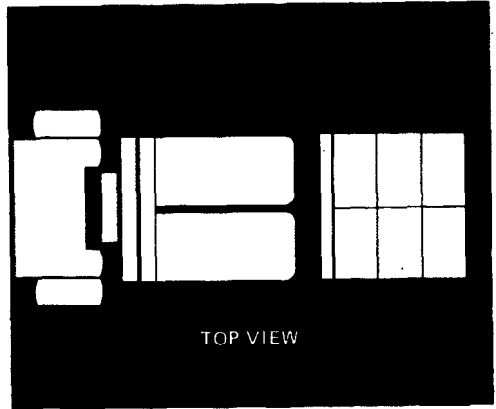

**2** Raise the platens to just above the slip sheet of the load you are picking up.

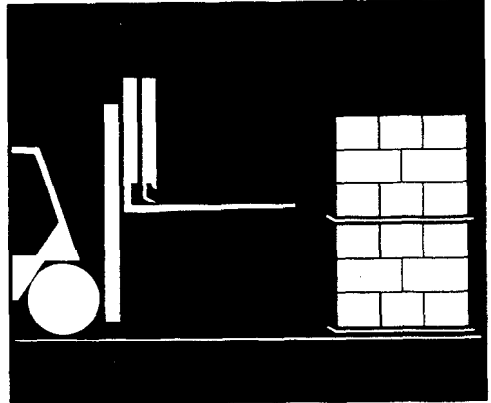

**3** Tilt the mast forward 3° to 4°.

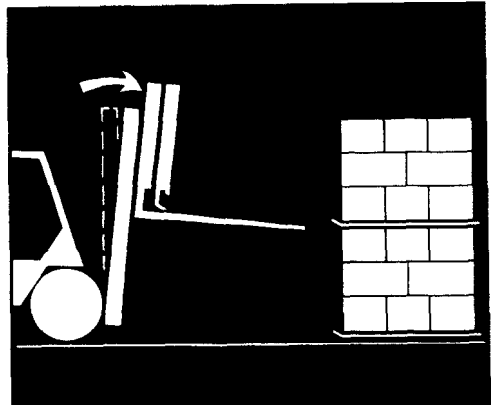

## Load Push/Pull Pickup from a Stack

**4** Drive the truck forward until the platen tips are under the slip sheet lip.

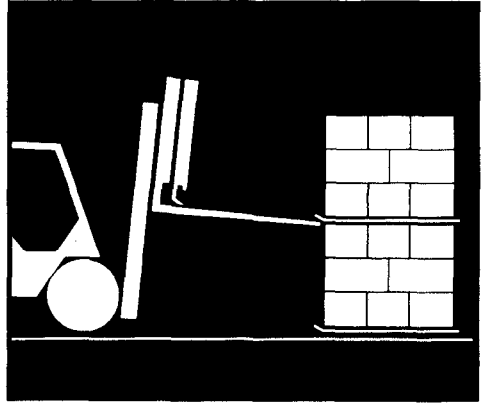

**5** Extend the pusher plate so the lip of the slip sheet fits into the gripper channel opening.

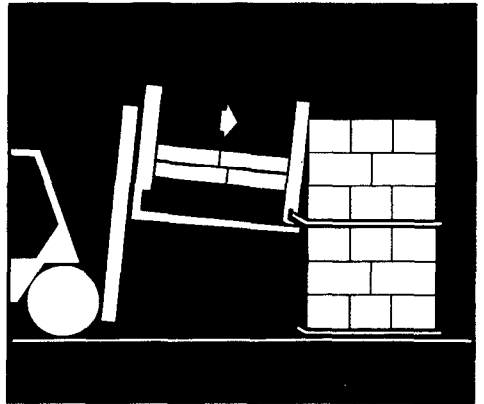

**6** Apply the truck brakes and retract the pusher plate. The gripper bar will automatically clamp the slip sheet lip.

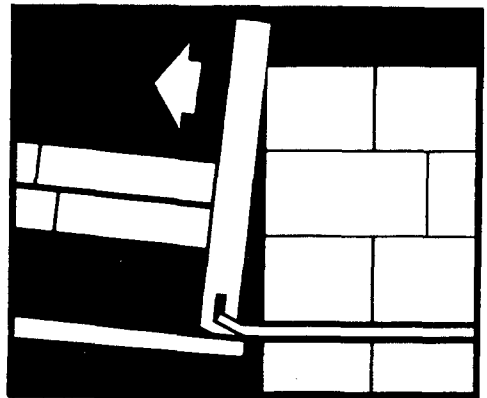

## Load Push/Pull

**7** Pull the load onto the platens. As the load reaches the platens they will deflect downward. Raise the carriage slightly to compensate for this.

*DO NOT* allow the truck to be pulled forward since the platen tips may gouge the load underneath.

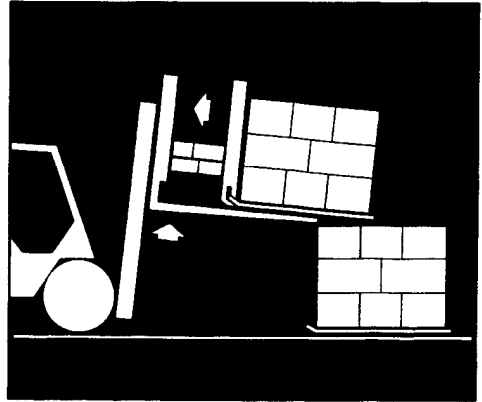

*NOTE:* Some operations use two slip sheets between the loads. In this case, insert the platens into the opening between the slip sheets and drive the truck forward as the load is being pulled onto the platens.

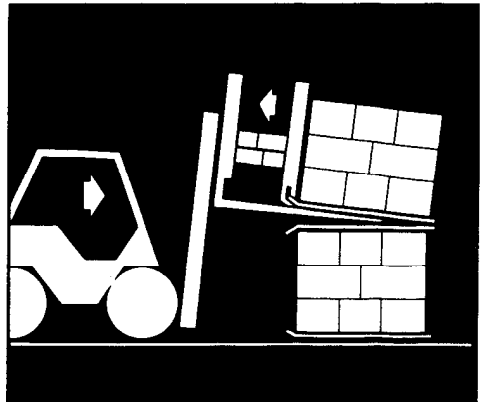

**8** Tilt the mast back and lower the load to 3"–4" above the floor. You are now ready to transport the load.

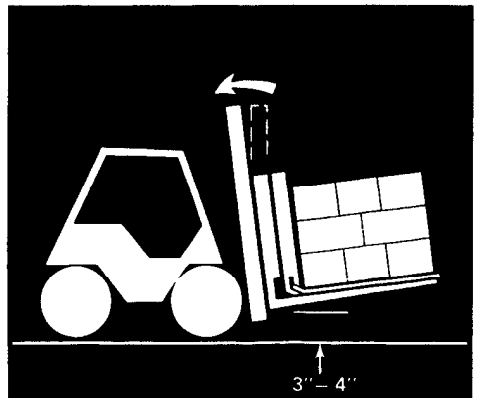

# Load Push/Pull Discharge

**1** Carefully position the load exactly above where it is to be discharged.

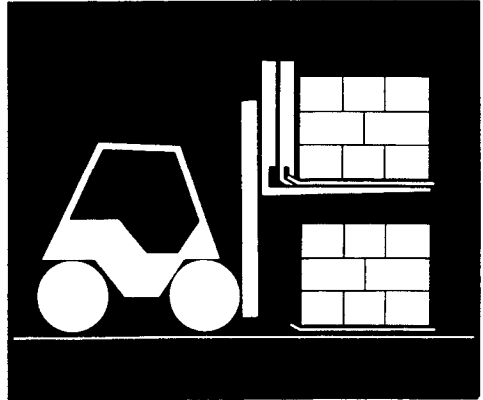

**2** Tilt the mast forward 3° to 4°.

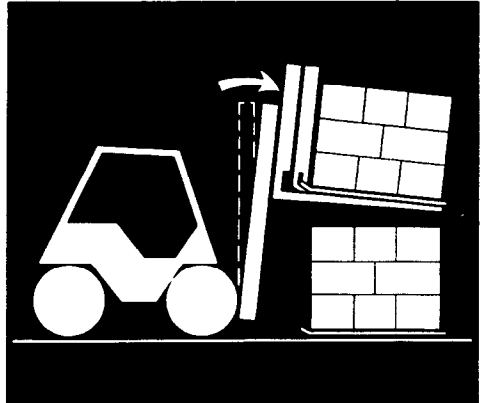

**3** Lower the carriage until the platen tips are about 1" above the discharging area.

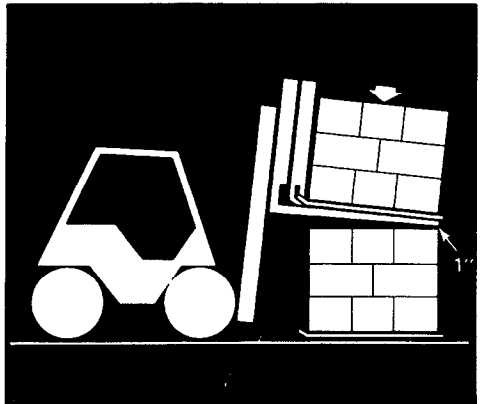

## Load Push/Pull

**4** Place the truck's transmission in neutral and start the pushing operation. The gripper bar will automatically release the slip sheet lip. As the pusher plate moves the load off, the truck will move backwards, (with light loads drive backwards slowly). As the weight is withdrawn from the platens they will deflect upward slightly. Compensate for this by lowering the carriage slightly.

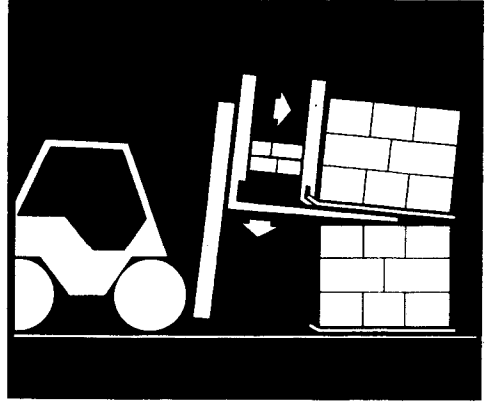

*NOTE:* If your truck does not operate in neutral, place the transmission in reverse and drive backwards slowly to coordinate the pushing motion with the reverse movement.

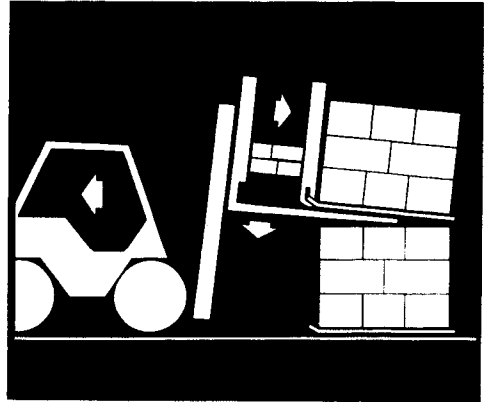

**5** Back away, tilt the mast back and raise or lower the platens to 3"-4" above the floor for traveling.

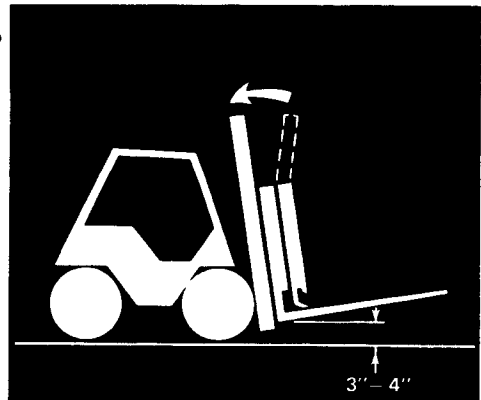

# Operator Techniques

## Pickup

Always enter the load with the platens at a downward angle, otherwise the tips will gouge the load.

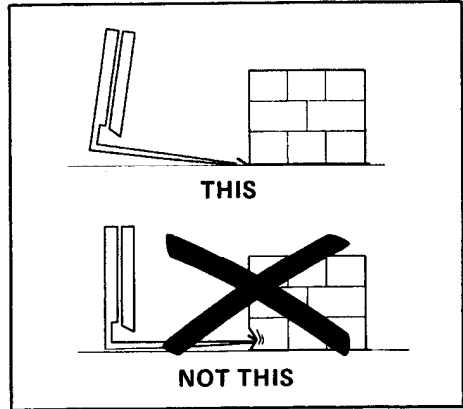

Pick up unitized loads or firmly stacked loads. Do not pick up sloppy or poorly distributed loads.

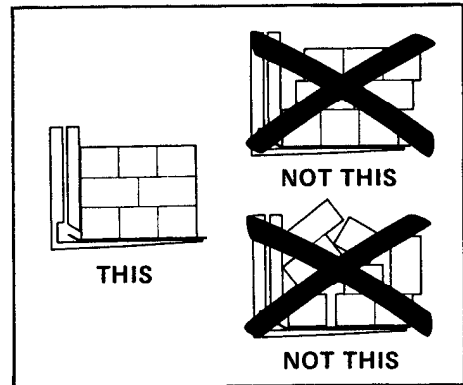

## Carrying a Load

Carrying more than one load at a time reduces operation and load security and is not recommended, unless an adequate backrest is used.

*CAUTION: All loads must be within the rated capacity of the truck/attachment combination.*

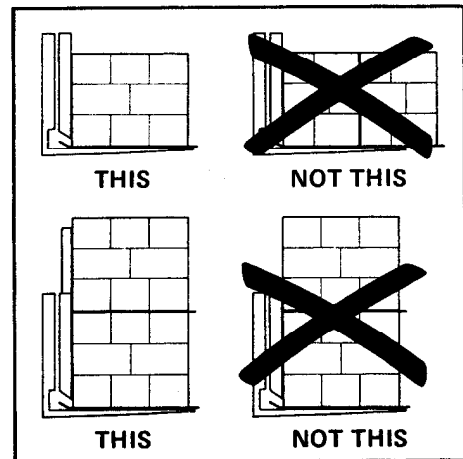

## “Milking”

“Milking” is an attempt to push harder or to grip harder by a single, quick application of the pushing lever, or by a series of quick applications. **AVOID “MILKING”!** It may damage the pushing mechanism, the hydraulic lines and the truck’s hydraulic system.

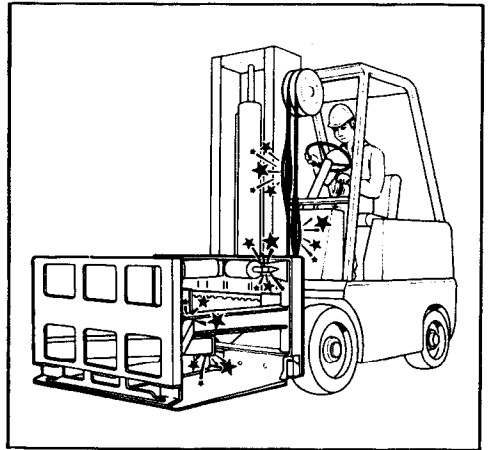

## Misaligned Pusher Plate

The pusher plate may extend irregularly or at an angle when the pusher plate has been accidentally hit or jarred on one side or when air has entered the system. Correct this by extending the pusher plate completely. Keep the control handle in the “extend” position for 10–20 seconds. This will circulate oil throughout the system. Retract the pusher plate fully and repeat the extension procedure again. In most cases two cycles will straighten the pusher plate.

As a check, with the pusher plate extended, grab the pusher plate and shove it from side to side while watching both push cylinders. The cylinder rods should not move. If either cylinder rod is “spongy”, the system may contain some air. Repeat the extension procedure again.

If the pusher plate will not realign, report the problem to your supervisor.

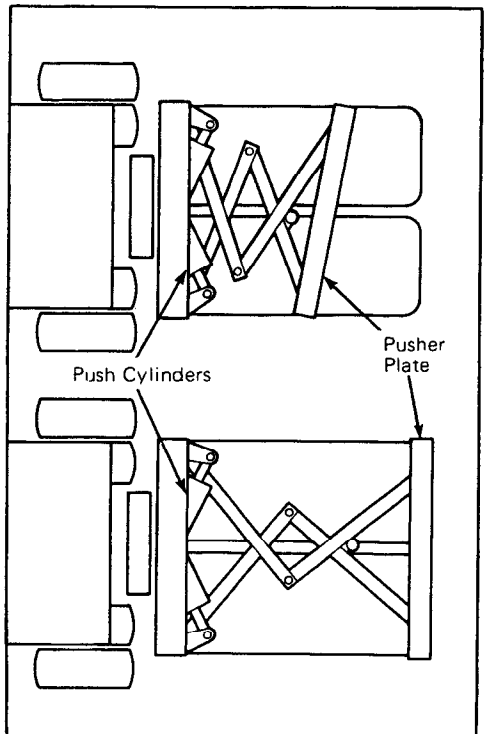

# Operator Safety Rules



Operator must be properly trained and qualified.



Drive carefully and observe traffic rules. Be in full control of the truck at all times. Avoid ruts, bumps, and other hazards that may cause the truck to swerve or tip.



Travel slowly around corners. Sound horn on blind corners. Be careful of tail swing and overhead clearances. Watch where you are going, whether in forward or reverse. Avoid sudden stops and starts.



Never leave a lift truck unattended without lowering the load to the floor, setting the brake, and turning the truck off.



Always back down ramps or inclines. Driving forward down a ramp or incline with a load will reduce the truck's stability.



Do not allow riders on the truck or platens at any time.



Do not lift or hit anything that may fall.



Never allow anyone under a load or under the carriage.



Never reach through the mast. Keep all parts of your body inside the driver's compartment.



Transport a load with the attachment 3–4 inches from the ground and the mast tilted back.



Limit the amount of truck maneuvering to a minimum when high-stacking a load.



Report all damaged or faulty equipment. Do not operate a lift truck or a Load Push or Load Push/Pull until repairs have been made.



Do not overload the lift truck. Make sure the load is within the attachment and trucks rated capacity, whichever is lower.



Do not open boxcar doors with this attachment.



Do not grip anything other than slip sheets with the gripping bar.



Do not use the Load Push or the Load Push/Pull as a “bulldozer” or a ram.



Perform the Daily Visual and Operation Inspections on page 23 before using the attachment on the job.



If in doubt about any procedure in this book, ask your supervisor.

# Optional Features

## Multiple-Stop Group

The optional multiple-stop group consists of two four-position cams mounted at the push/pull cylinder rod ends as shown. These cams allow you to handle four different load lengths using the same platens (shown below). Their purpose in limiting retraction of the pusher plate is to prevent the platens from protruding beyond the end of the unit-load being carried, and possibly damaging the loads already stacked.

To adjust for pusher plate retraction:

1. Extend the pusher plate beyond where the stop is needed. Example: For the 3'' limit, extend the pusher plate at least 4''.
2. Depress the latch from its slot.
3. Rotate the cam to the numbered slot needed (0 = 0'', 1 = 3'', 2 = 6'', 3 = 9''). Example: For 3'' limit, rotate the cam to the numbered 1 slot.
4. Release the latch in this slot.

**CAUTION:** Be sure that both of the cams are set on the same number.

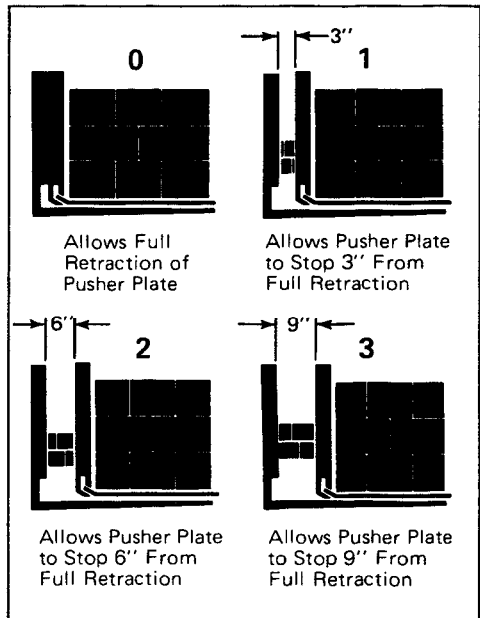
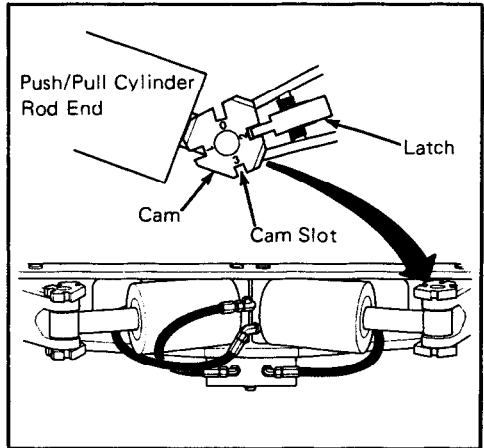

# Sheet Sav®

The Sheet Sav option - controlled from the driver's seat - gives you the added ability to retain the slip sheet as the load is discharged.

The sheet retaining mechanism consists of a special second gripper bar in the frame that automatically holds the slip sheet on the platen while the load is pushed off.

The following shows the operation of the Sheet Sav.

**1** Load is pulled onto platens with regular gripper mechanism.

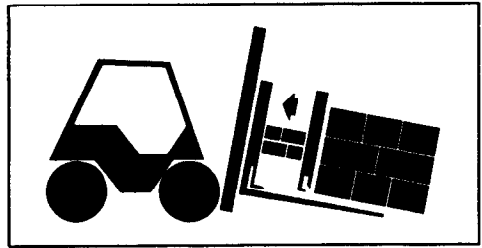

**2** Gripper bar opens. Sheet Sav mechanism raises automatically, releasing sheet from gripper jaw.

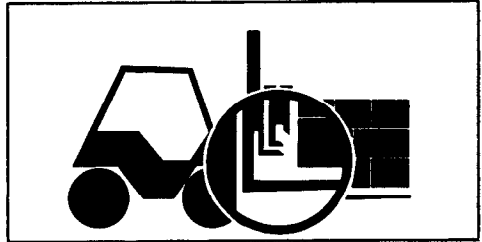

**3** Sheet Sav mechanism moves down to retain sheet.

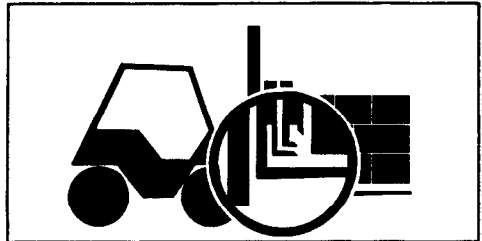

**4** Pusher Plate pushes load off platens while slip sheet is retained.

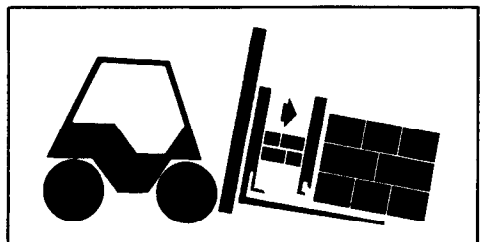

# Hydraulic Adjustable Platens

The hydraulic adjustable platen option allows you to handle pallets or palletized loads in addition to slip sheets.

The hydraulic adjustable platens are controlled from the driver's seat and provide a full 5" of movement.

The illustrations show the applications for hydraulic adjustable platens.

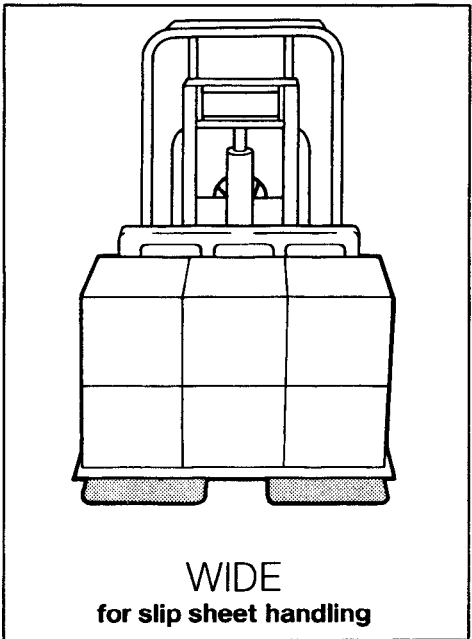
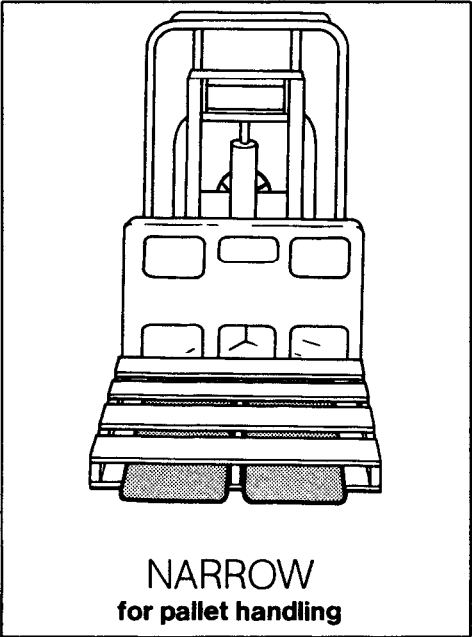

# Tilting Pusher Plate

The tilting pusher plate option is designed to reduce the risk of damage to cartons and increase ease of operation while handling unit loads on slip sheets.

The operation of the tilting pusher plate is shown in the following steps.

**1** The lift truck with a push/pull attachment approaches the load and the tilting pusher plate makes contact with the load.

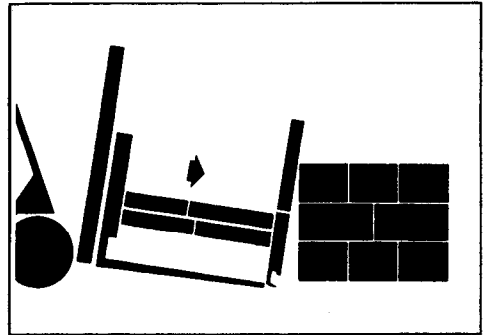

**2** As the pusher plate engages the load, the tilting pusher plate begins to pivot, and adjusts to the load. The pusher plate can tilt to a maximum of 10°.

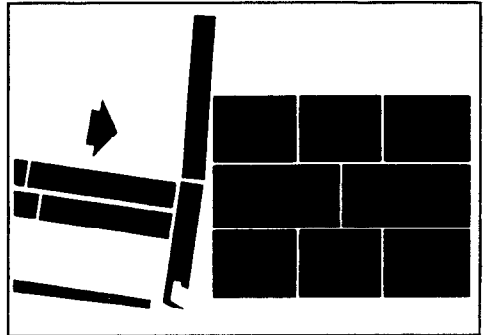

**3** In this step the tilting pusher plate has completely adjusted to the load. The gripper jaw retains the slip sheet lip and the load is ready to be pulled onto the platens.

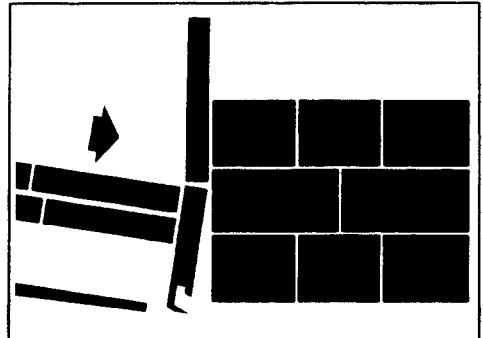

# Daily Inspection

Perform the following visual and operation inspections daily before taking the attachment on the job. If any one of the inspection items does not check out, report it to your supervisor. Do not operate the attachment on the job until all repairs have been made. See the **Service Manual** for procedures on repairs.

## Visual Inspection

- ☑ Check to see that all fittings are tight and that hoses are attached securely and do not leak.
- ☑ Check for tightness and correct mounting of mounting bolts, capscrews, nuts and hooks.
- ☑ Check the platen tips for nicks or other damage. Repair immediately. Flatten out nicks with a hammer and smooth the edges with a file or grinder. Apply wax or paraffin to the top surfaces of the platens to reduce friction between platens and slip sheets. Use a piece of steel wool to remove excess wax.
- ☑ Check to see that platens are not too long or too short for the unit-loads being carried. If so, replace with platens of the correct length, or adjust the multiple stop cams (if attachment is so equipped).

## Operation Inspection

Perform the following inspections, first without a load, and again after picking up a load.

- ☑ Check to be sure the pusher plate moves in and out smoothly and that it does not work at an angle or appear to be twisted.
- ☑ Check to be sure the capscrews that hold the platens on the lower bar are tight.



**cascade  
corporation**

P.O. Box 20187  
Portland, OR 97220  
Phone: (503) 666-1511

11/78

Part No. C-665357