

Technical Bulletin

200D Rotator and Revolving Clamp Mounting Capscrew Torque Values

This sheet provides instructions to install mounting capscrews to the attachment baseplate.



WARNING: Failure to follow these steps to install the mounting capscrews may cause machine damage and or bodily injury.

- 1 Install the mounting brackets or mount the attachment to the truck carriage using M24 x 3 (3 mm pre thread) grade 8.8 metric capscrews. Capscrew threads must engage the full depth of the baseplate.
- 2 Lube the capscrews, then tighten to a torque of 470-520 ft.-lbs. (637-704 Nm).
- 3 Inspect and tighten the capscrews at 100 hour intervals.

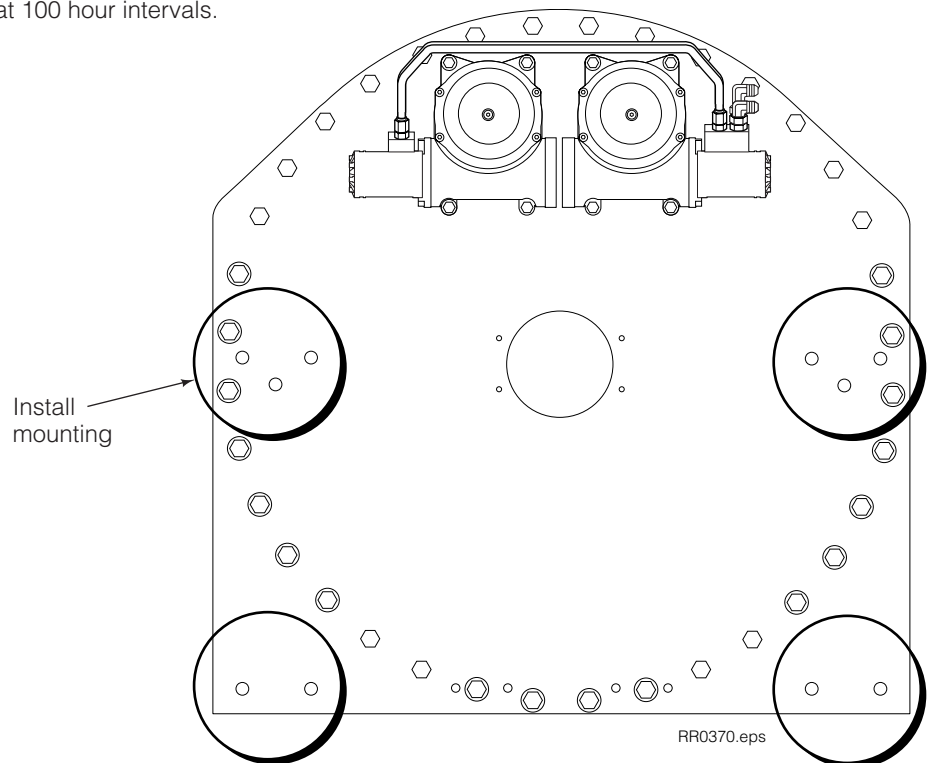

NOTE: This information should not be interpreted as the basis for warranty claims unless so designated.

cascade[®]
corporation

For Technical Support . . .

Call: 1-800-227-2233 Fax: 1-888-329-8207

Internet: www.cascorp.com

Write: Cascade Corporation, PO Box 20187, Portland, OR 97294

© Cascade Corporation 1989

To Order Parts . . .

Call: 1-888-227-2233 Fax: 1-888-329-0234

Internet: www.cascorp.com

Write: Cascade Corporation, 2501 Sheridan Ave., Springfield, OH 45505

7-1989

Part No. 686508