



Installation Instructions

Upper Hook Replacement Kit 6009962 for Class II D & E-Series Carton Clamps

This sheet describes the installation of new upper mounting hooks for Cascade Carton Clamp Models 30E, 33E, 35D, and 45E with Class II bolt-on type hooks. The upper hooks can be replaced without removing the Carton Clamp from the truck by following the procedure below.

- 1 Lower the Carton Clamp onto a pallet so that the Clamp's weight is off the carriage bars.
- 2 Remove and replace the upper hooks with the new hooks and capscrews provided in the kit. Lubricate the capscrews and tighten only lightly at this point.
- 3 Slowly ease the carriage up to align the upper hooks with the carriage bar. Do not put the full weight of the Clamp on the hooks. **IMPORTANT:** Hooks must be square to carriage bar for proper engagement.
- 4 Double-torque the capscrews using the following procedure: tighten to the final torque value of 235 ft.-lbs. (320 Nm), loosen 1/2-turn, immediately retighten to 235 ft.-lbs. (320 Nm).
- 5 Check and adjust, if necessary, the lower hook clearance as shown below.

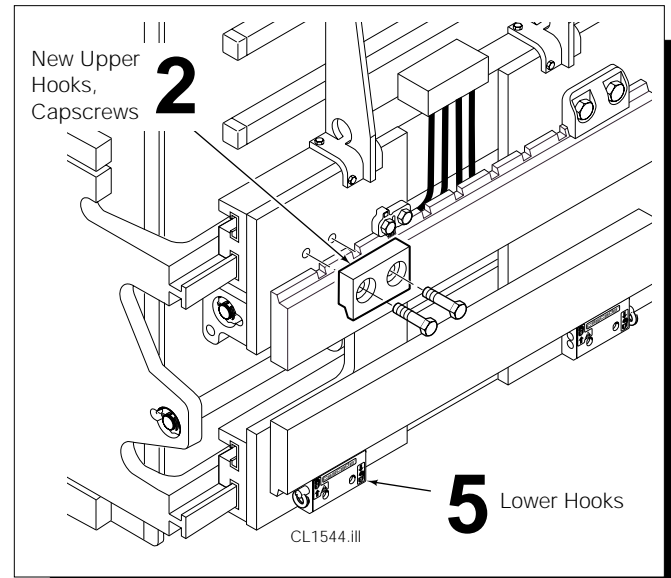

Quick Disconnect Lower Hook

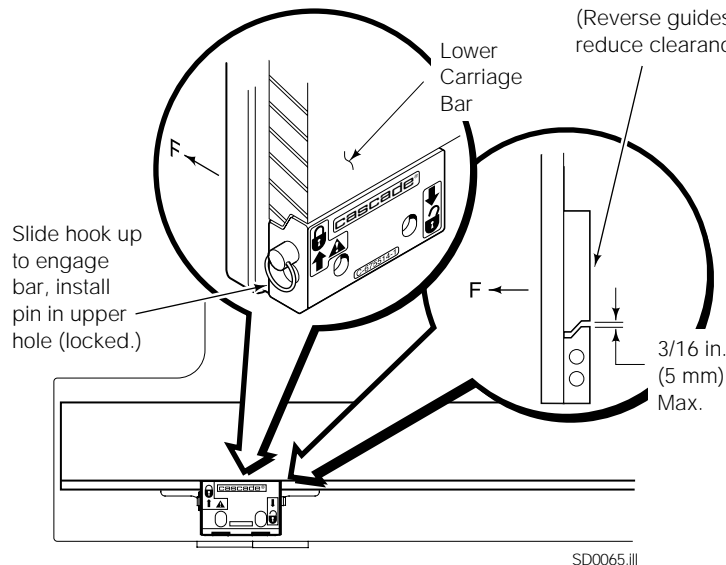

Bolt-On Lower Hook

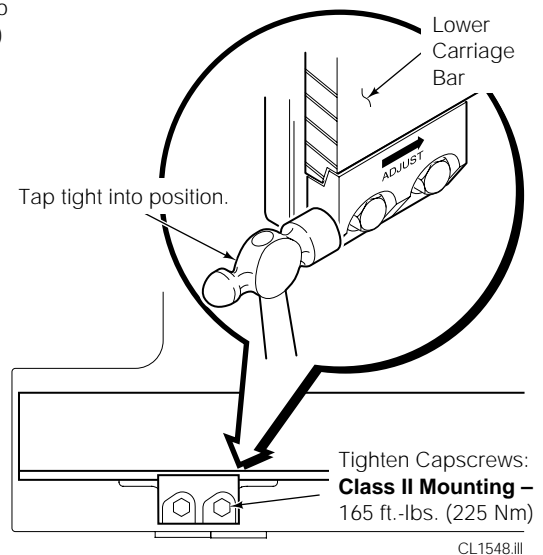

NOTE: This information should not be interpreted as the basis for warranty claims unless so designated.

cascade®

For Technical Support . . .

Call: 1-800-CASCADE (227-2233)

OR

Write: Cascade Corporation, PO Box 20187, Portland, OR 97294-0187

To Order Parts . . .

Call: 1-888-CASCADE (227-2233)

OR

Write: Cascade Corporation, 2501 Sheridan Ave., Springfield, OH 45505