



# Technical Bulletin

## 45E Push/Pull Platen Modifications for Block Pallet Handling

This sheet describes the procedures to modify E-Series Push/Pulls with 1 in. thick platens to be compatible with block-style pallets with 12 in. wide fork pockets. Optionally, the platens may be returned to the Factory for modification, or new 11-in. (280 mm) wide platens may be purchased.

**CAUTION:** These modifications derate the load handling capacity of a 45E Push/Pull with 1 in. thick platens to 3200 lbs. Removing platen surface area may cause load instability while handling slip sheet loads. **If modifications are made in the field, obtain a new Attachment nameplate to show the lower capacity rating** (see Step 6).

- 1 Lay out the cut lines on the platens as shown. Mark a cut line 1 in. from the inside edge of the platen, then another cut line from the new edge that will result in a finished platen width of 11 in. (280 mm). Begin all cuts 1 in. (25 mm) in front of the platen weld area (see illustration).
- 2 Cut along the marked lines using a mill or cutting torch (plasma cut preferred), and a steel bar as a straight edge. **IMPORTANT:** Mill cut preferred. If cutting torch used, cut as quickly as possible to limit heat input into the platen base metal.
- 3 Normal air cool the platen, then grind away the 1/16 to 1/8-in. (1.6 to 3.2 mm) heat affected zone (HAZ) to form a smooth edge. Finish with the grind marks in the grain direction of the platen. Remove or blend any sharp edges or deep cuts.

 **WARNING:** Cascade Corporation recommends that a qualified welder experienced in this type of repair be used for best quality.

- 5 Regrind the tip edge blends to conform to the original Cascade specification.
- 6 Use this Technical Bulletin to order a new nameplate by filling in the requested information (see box below) and sending the sheet to Cascade Service in the U.S. at: FAX 888-329-8207.

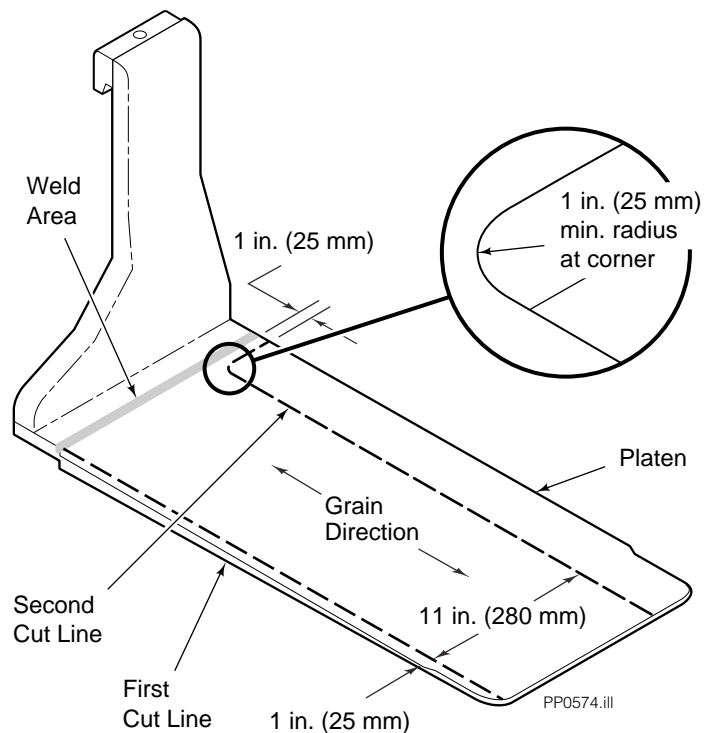

**NAMEPLATE ORDER FORM**  
FAX to: 888-329-8207

Dealer Name \_\_\_\_\_

Address \_\_\_\_\_

Original Attachment Model \_\_\_\_\_

Serial Number \_\_\_\_\_

Please provide the following contact information of the person who accomplished the modifications:

Name \_\_\_\_\_

Phone \_\_\_\_\_

**NOTE:** This information should not be interpreted as the basis for warranty claims unless so designated.



For Technical Support . . .

Call: 1-800-227-2233

OR

Write: Cascade Corporation, P.O. Box 20187, Portland, OR 97220

To Order Parts . . .

Call: 1-888-227-2233

OR

Write: Cascade Corporation, 2501 Sheridan Ave., Springfield, OH 45505