



Technical Bulletin

30C/45C Load Push/Pull Gripper Cylinder Service Kit 559282 and 559971

This sheet provides instructions for 30C/45C Load Push/Pull Gripper Cylinder Service Kit 559282 (includes seals and a new retainer). Seal Kit 559971 contains the seals only.

Cylinder Removal

- 1 Remove the cotter pins from the anchor pins retaining the gripper cylinder rod to the gripper bar.



WARNING: Before removing any hoses, relieve pressure in the hydraulic system. Turn the truck off, then open the truck auxiliary control valve(s) several times in both directions.

- 2 Remove, tag and plug the hoses to the gripper cylinder.
- 3 Remove the nut retaining the cylinder to the faceplate and pull out the cylinder.

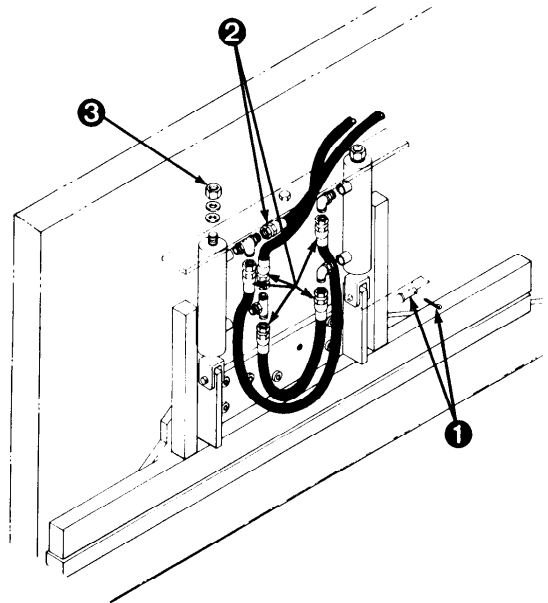

Cylinder Service

- 1 Remove the snap ring.
- 2 Remove the retaining ring by first tapping the retainer into the shell. Place a screwdriver on one side of the ring and tap the screwdriver with a hammer. Take care not to gouge the shell bore with the screwdriver. The retainer ring will compress at the split and turn sideways as shown at right. Remove the retaining ring.
- 3 Pull the rod assembly out of the shell.

(Continued)

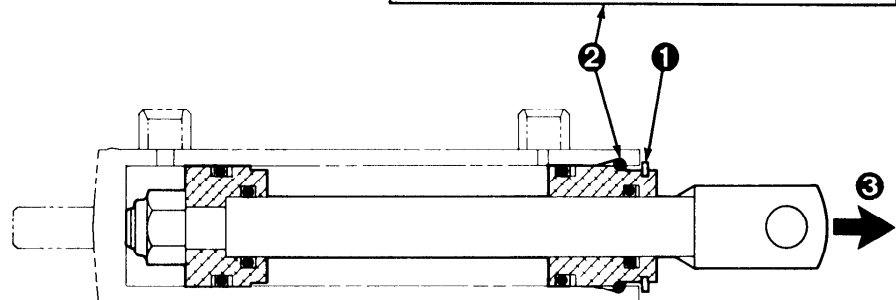
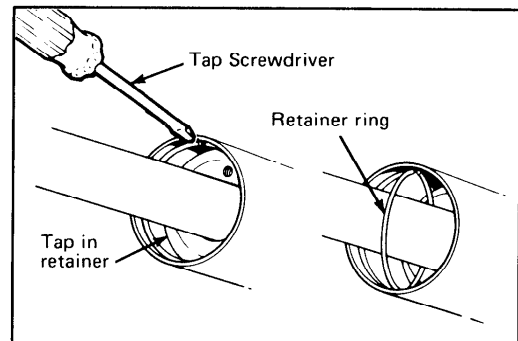

NOTE: This information should not be interpreted as the basis for warranty claims unless so designated.
Part No. 559281

cascade®

For Technical Assistance . . .

Call/ 1-800-CASCADE or 503-669-6300

OR

Write: Cascade Corporation, P.O. Box 20187, Portland, OR 97220

To Order Parts . . .

Call: 513-322-1199

OR

Write: Cascade Corporation, P.O. Box 360, Springfield, OH 45505

- ④ Remove the nut fastening the piston to the rod.
- ⑤ Remove the piston and retainer from the rod.
- ⑥ Remove and replace the piston seals. **Discard the old retainer and install seals on the new retainer.**
- ⑦ For reassembly, reverse the above procedures except as follows:
 - Tighten the piston nut to a torque of 40-45 ft.-lbs.
 - Tighten the cylinder anchor nut until rigid against the faceplate, then back off one turn.

NOTE: Once a new retainer has been installed, the cylinder can be serviced with Seal Kit 559971.

