

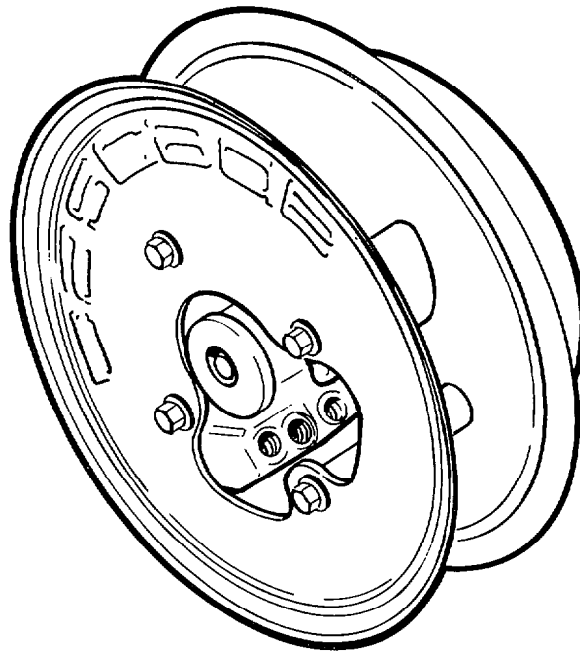

Installation and Service Manual

THINLINE™ 4 Port Hose Reel



Manual Number 675395 R-1

cascade®

Cascade is a Registered Trademark of Cascade Corporation • THINLINE is a Trademark of Cascade Corporation

Contents

| | Page |
|---|------|
| Introduction, Section 1 | i |
| Truck Requirements | i |
| Special Definitions | i |
| Installation, Section 2 | 1 |
| Hose Reel Installation | 1 |
| Cascade Masts | 1 |
| All Other Masts | 1 |
| Hose Installation | 2 |
| Hose Length Calculations, Section 3 | 4 |
| Periodic Maintenance, Section 4 | 4 |
| Troubleshooting, Section 5 | 5 |
| Service, Section 6 | 6 |
| Hose Reel Removal | 6 |
| Hose Replacement | 7 |
| Flange and Hub Removal | 8 |
| Spring Assembly Replacement | 8 |
| Hub Seal Replacement | 9 |
| Reversing the Reel Assembly | 10 |

Section 1 Introduction

This manual contains the installation, periodic maintenance, troubleshooting procedures and service information for the Cascade THINLINE™ 4-Port hose reels. If you have questions, call the Cascade Service Department at the location nearest you. See the back cover for a list of the locations.

1.1 Truck Requirements

Pressure: 3000 psi (210 bar) maximum.

Volume—Recommended flows:

No. 4 – 2.5 gpm (10 L/min)

No. 6 – 6 gpm (25 L/min)

CAUTION: If the track flow through the reel exceeds 10 gpm (38L/min), call the Cascade Service Department location nearest you.

1.2 Special Definitions

▲ WARNING

A statement preceded by **▲WARNING** is information that should be acted upon to prevent **bodily injury**. A **WARNING** is always inside a ruled box.

CAUTION

A statement preceded by **CAUTION** is information that should be acted upon to prevent **machine damage**.

IMPORTANT

A statement preceded by **IMPORTANT** is information that possesses special significance.

NOTE

A statement preceded by **NOTE** is information that is handy to know and may make your job easier.

Section 2 Installation Instructions

2.1 Hose Reel Installation

2.1-1 Cascade Masts

- 1 Attach the hose reel mounting bracket to the mast crossbar. Leave the capscrews finger tight until the hose reel is attached to the bracket and positioned for correct clearance with the mast upright.
- 2 Attach the hose reel to the mounting bracket with the capscrews supplied. Tighten the capscrews to a 30–35 ft.-lbs. (40–47 N·m).
- 3 Adjust the hose reel to 1/4" clearance between the reel inner flange and mast upright. Tighten the mounting bracket capscrews to a torque of 15–20 ft.-lbs.
- 4 Drill out the threads in one of the hose restraint mounting block holes with a 3/8" dia. drill as shown.
- 5 Attach the hose restraint mounting block to the mast upper carriage bar using the middle hole. Tighten the capscrew to a torque of 15–20 ft.-lbs. (20–27 N·m).

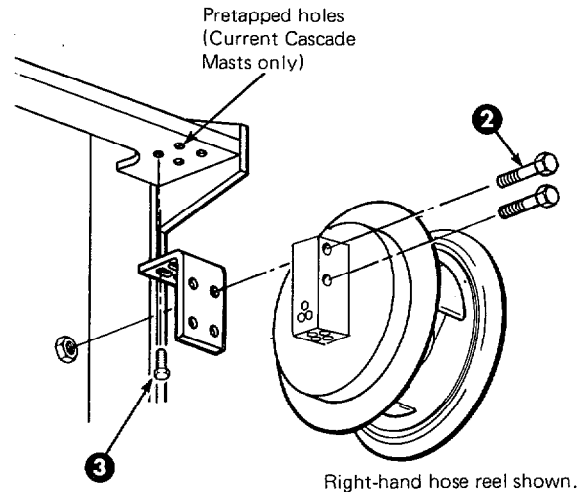

Right-hand hose reel shown.

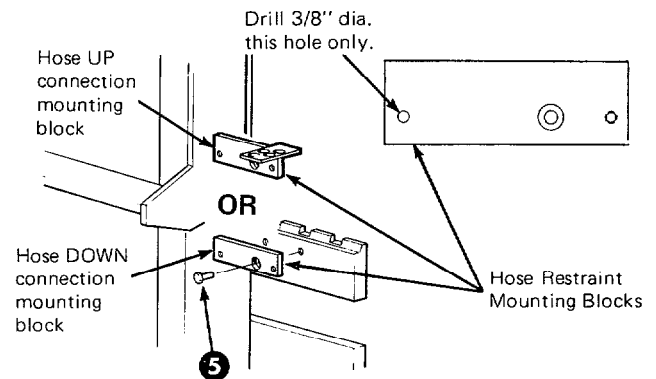

2.1-2 All Other Masts

- 1 Select a mounting location for the hose reel. The preferred location is near the upper mast crossbar. Mark the required bracket position.
- NOTE:** The hose reel must meet all minimum clearances shown below.

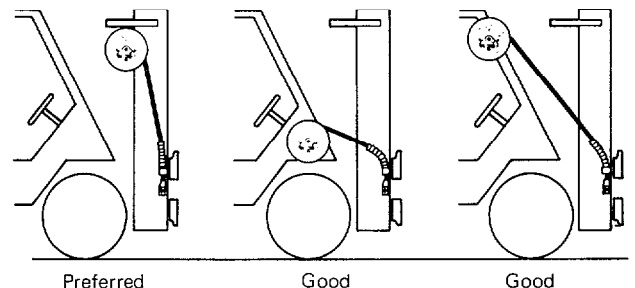

- 2 Disconnect the truck alternator.

- 3 Weld the mounting bracket to the upright with 3/16" fillets using AWS E60XX weld rod. No preheat or post heat is required. Protect adjacent mast parts from weld splatter.

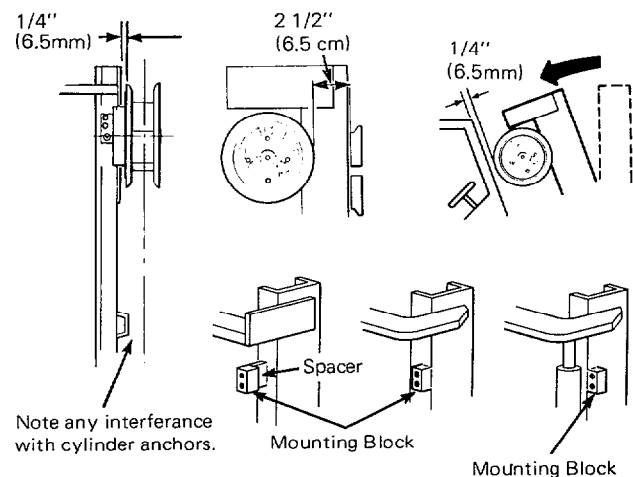

Section 2 Installation Instructions

2.1-2 All Other Masts (Continued)

- 4 Attach the hose reel to the mounting block with the capscrews supplied. Tighten the capscrews to a torque of 30–35 ft.-lbs. (40–47 N·m). Check the clearance as shown in step 3.

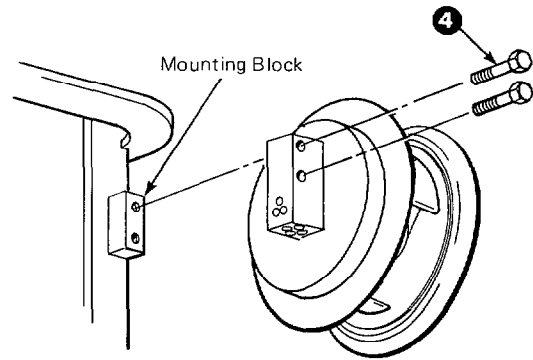

- 5 Use a square to find the reel centerline. Position the hose restraint mounting block on the upper carriage bar centering the two outer holes with the hose reel as shown.
- 6 Weld the mounting bracket to the upper carriage bar with 3/16" fillets using AWS E60XX weld rod. No preheat or post heat is required. Protect adjacent mast parts from weld splatter.

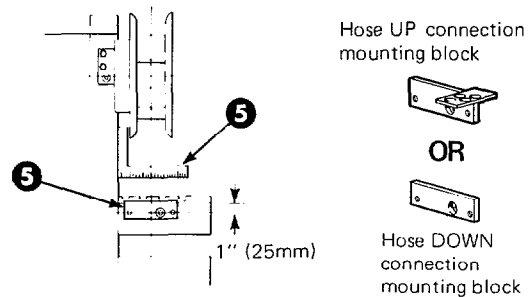

2.1-3 Hose Installation

- 1 Press and twist the hose assemblies into the hose restraint. Spray hoses with WD-40 to make installation easier.

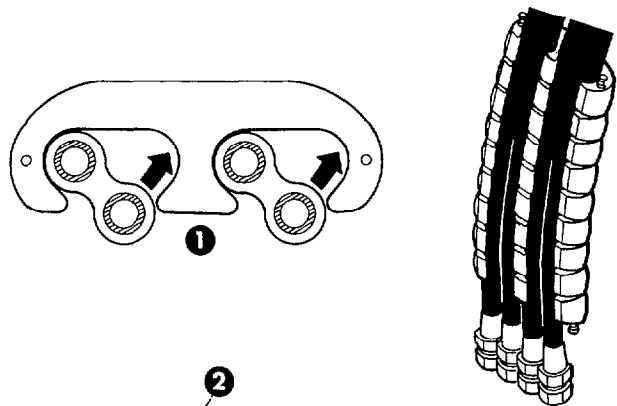

- 2 Install the fittings and hose ends (inside fitting first) to the hose reel hub. Hold hoses while tightening to prevent from twisting.

NOTE: Install the hoses with the natural set in the direction of wind.

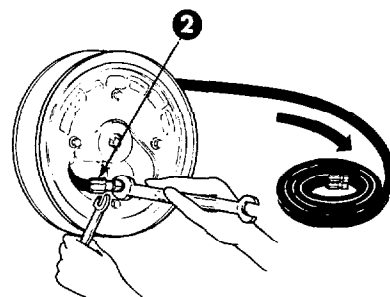

- 3 Wind the hoses onto the hose reel in the direction shown in the illustration.

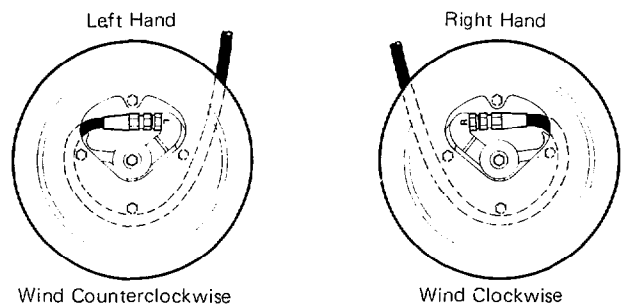

NOTE: See Section 6-6 for Reel Assembly reversal.

Section 2 Installation Instructions

2.1-3 Hose Installation (Continued)

- 4 Raise the truck carriage to just below the hose reel.
- 5 Prewind the hose reel the number of turns and direction shown in the chart below.

| Hose/Flange Size | Prewinds | Max. Turns |
|------------------|----------|------------|
| No. 4/15" | 5 | 11 |
| No. 6/13" | 5 | 13 |
| No. 6/16" | 5 | 13 |

2149m-1

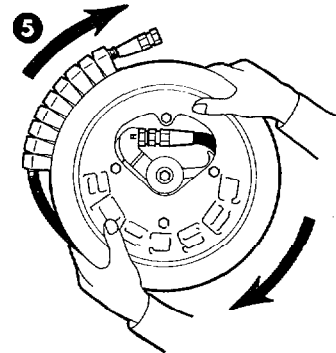

- 6 Attach the hose restraint to the mounting block with the clamp. Install the clamp between the first and second hose restraint segments.

CASCADE MASTS: Use the 3/8 NC x .75 capscrew supplied in the inner hole of the clamp.

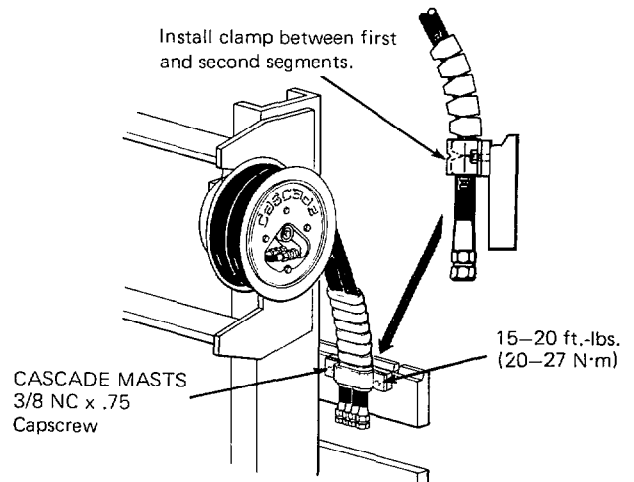

- 7 **Hose Up Connection** - Install the tubes and fittings to the mounting block and hose ends.

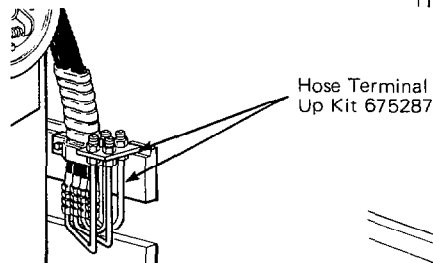

- 8 Connect the hoses from the truck auxiliary valve to the hose reel mounting block.

NOTE: The mounting block ports are marked for identification.

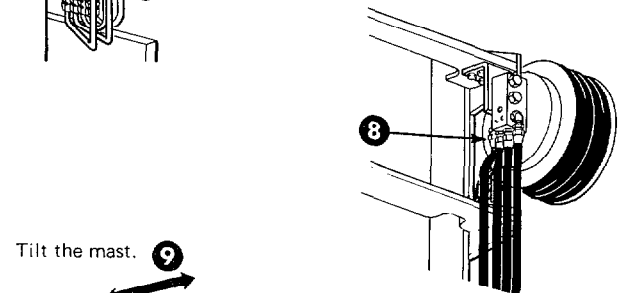

- 9 Tilt the mast back and forth. Raise and lower the carriage. Check for clearance problems.

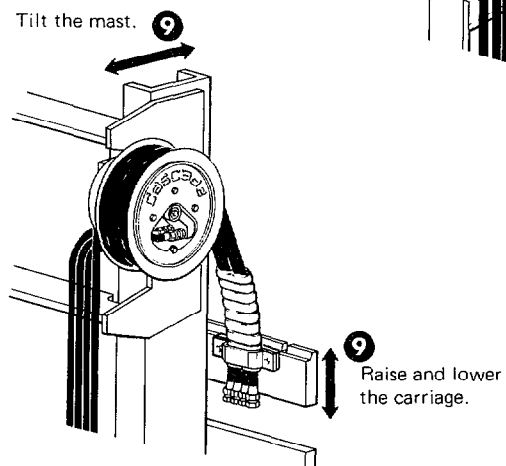

Section 3 Hose Length Calculation

3.1 Hose Length Calculations

H = Total lift height

D = Distance from centerline of reel to hose end with carriage fully lowered.

K = CONSTANT = 18 inches (460 mm) for No. 4
= 28 inches (710 mm) for No. 6

1. When **H** is equal to, or greater than $2 \times \mathbf{D}$ the correct hose length is:

$$\mathbf{H} - \mathbf{D} + \mathbf{K}$$

2. When **H** is less than $2 \times \mathbf{D}$ the correct hose length is:

$$\mathbf{D} + \mathbf{K}$$

Example inches

H = 286"

D = 96"

K = 28"

$286'' - 96'' = 190'' + 28'' = 218''$ correct hose length.
In this case, use hose 675286.

Example mm

H = 7265mm

D = 2440mm

K = 710mm

$7265 - 2440 = 4825 + 710 = 5535$ correct hose length in this case, use hose 675286.

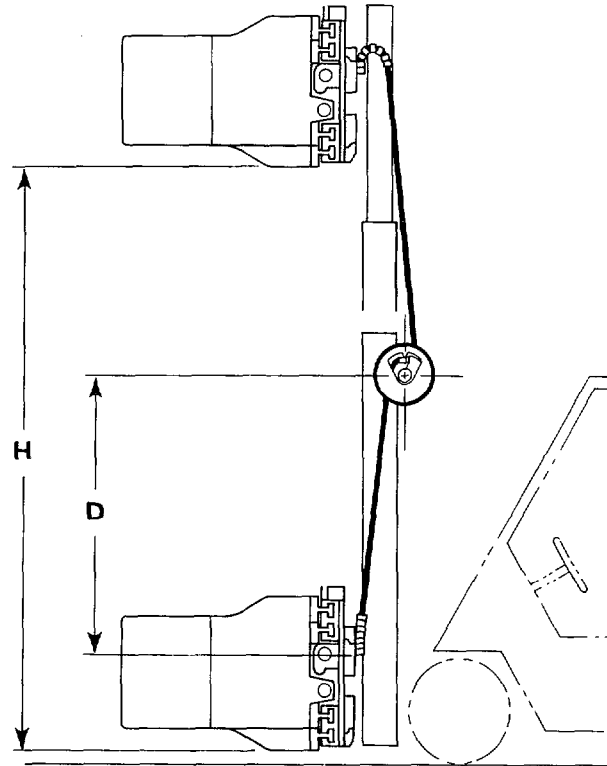

Section 4 Periodic Maintenance

4.1 500 Hour Maintenance

After each 500 hours of lift truck operation, perform the following procedures.

- Tighten the mounting capscrews. Use the torque specifications shown in Section 6.1.
- Tighten all hydraulic hose fittings.

Section 5 Troubleshooting

5.1 Troubleshooting Guide

| PROBLEM | PROBLEM CAUSE | SOLUTION |
|--|--|--|
| Excessive wear on hose. | Hose reel and hose terminal are not in proper alignment. | Align the hose terminal and hose reel properly. They must be on the same centerline and mounted squarely to each other. |
| | Hose reel flanges damaged. | Repair or replace damaged parts. |
| Hose jumps off reel during operation. | Hose reel not aligned with hose terminal. | Align hose terminal with hose reel. |
| | Incorrect prewind of spring. | Prewind spring. |
| Hose binds during operation. | Hose reel spring is broken. | Replace the spring. |
| | Flanges are bent. | Straighten or replace flanges. See Page 9. |
| Hose reel leaks at hub. | Worn or cut seals in the rotating hub. | Replace all rings. When a hose reel requires immediate replacement of any one of the O-rings or back-up rings, it is important that all the rings be replaced. If all the rings are not replaced at the same time, the reel will only have to be disassembled again in a short period of time to replace the older rings. The seal kit offered by Cascade includes all of the O-rings and back-up rings necessary to rebuild one hose reel. Order Seal Kit No. 674408. |
| | Loose or damaged fittings. | Tighten or replace damaged fittings. |
| | Scored seal areas. | Replace the damaged shaft or use an emery cloth (320 grit) to remove the nicks from the shaft or hub. |
| Hose reel leaks at mounting block and shaft. | Truck flow volume exceeds hose reel rating. | Install Flow Control Valve Part No. 671825 to reduce flow to 10 GPM (38 L/min) maximum. |

27096e-192/5

Section 6 Service

6.1 Hose Reel Removal

NOTE: To service the hub and flanges it is not required that the reel assembly be removed from the truck. All service procedures can be performed with the reel mounted on the mast. For purposes of this manual, all repairs will be done on the work bench.

- 1 Remove the twinline hoses from the hose terminal. For reassembly, tighten the hose terminal clamp capscrews to 15–20 ft.-lbs. (20–27 N·m).



WARNING: Hold hoses firmly while disconnecting them from the carriage. Allow the reel spring to unwind slowly while maintaining tension on the loose hose ends. Note the number of prewinds while unwinding the hose reel.

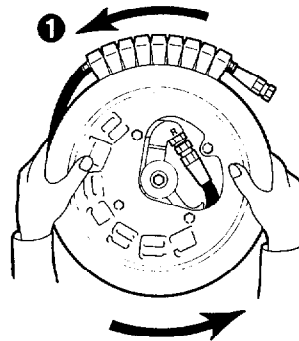
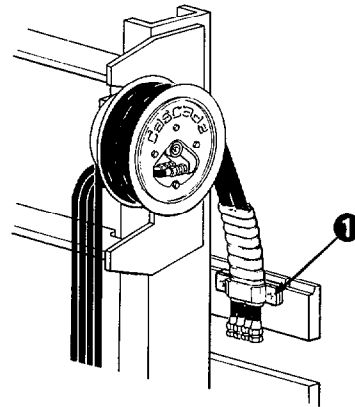

Right Side shown.

- 2 Disconnect the truck valve hoses from the hose reel mounting block. Tag the hoses for reassembly.
- 3 Remove the capscrews and self-locking nuts fastening the reel to the mounting bracket. Remove the reel from the mast. For reassembly, tighten the capscrews to 30–35 ft.-lbs. (40–47 N·m).

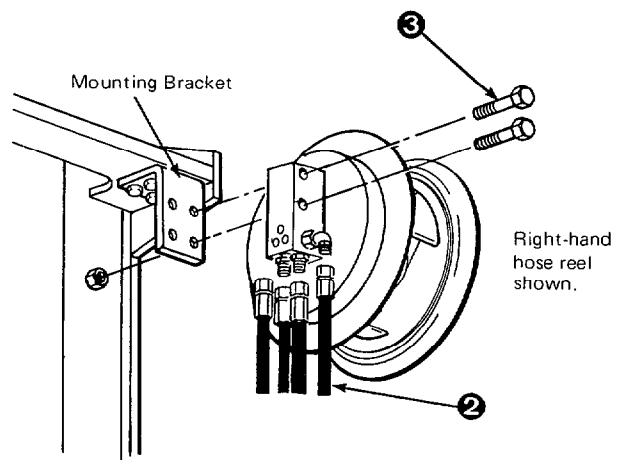

- 4 Determine whether the reel is a right or left hand model (viewed from the flange side of the reel). **This must be noted for future reference.** If the reel is left-handed, an "L" will show on the hub casting. If the reel is right-handed, an "R" will show on the hub casting.

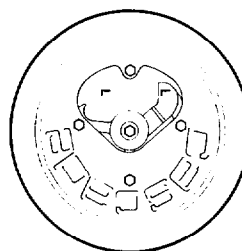

Left Hand Reel

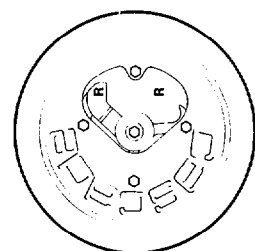

Right Hand Reel

6.2 Hose Replacement

- 1 Disconnect the twinline hoses from the hose terminal.



WARNING: Hold hoses firmly while disconnecting them from the carriage. Allow the reel spring to unwind slowly while maintaining tension on the loose hose ends.

- 2 Count the number of prewinds while unwinding the hose reel.
- 3 Disconnect the hoses from the reel hub. It is not necessary to remove the outer flange.
- 4 Remove the hoses from the reel.
- 5 Connect the new hoses to the reel hub fitting.

NOTE: Thermoplastic twinline hose has a natural bend or set. Wind the hose with the bend of the hose matching the flange bend. Do not twist hose when tightening fittings. Hold the fittings with a wrench when tightening.

- 6 Wind the new hose assembly completely onto the reel in the direction indicated (viewed from the flange side):

Right Hand Reel: Wind hoses clockwise.

Left Hand Reel: Wind hoses counterclockwise.

A Right or Left hand reel is determined as viewed from the flange side of the reel. An "R" or "L" letter on the hub casting will designate the correct direction.

- 7 Remove the old hose from the hose restraint by twisting out. Spray new hoses with WD-40 then install by twisting and pressing on.
- 8 Prewind the reel spring by grasping the end of the hose and turning the reel the specified number of complete turns in the direction indicated (viewed from the flange side).

Right Hand Reel: Wind reel clockwise.

Left Hand Reel: Wind reel counterclockwise.

Normal prewinds = No. 4-15 - 5 turns
 No. 6-13 - 5 turns
 No. 6-16 - 5 turns

If more tension is required, the reel can be prewound additional turns. The maximum total turn capacity of the reel is:

No. 4-15 - 13 turns
 No. 6-13 - 13 turns
 No. 6-16 - 13 turns

Total Turns = Prewind Turns + Working Turns

Caution: Exceeding the total turn capacity of the reel will damage the reel spring.

- 9 Reconnect the hoses to the hose terminal. Tighten the hose terminal capscrews to 15-20 ft.-lbs. (20-27 N·m).
- 10 Raise and lower the mast carriage slowly to ensure adequate hose length and alignment on reel.

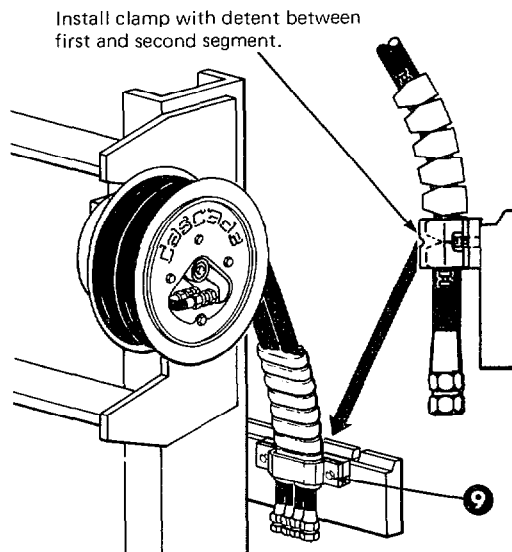
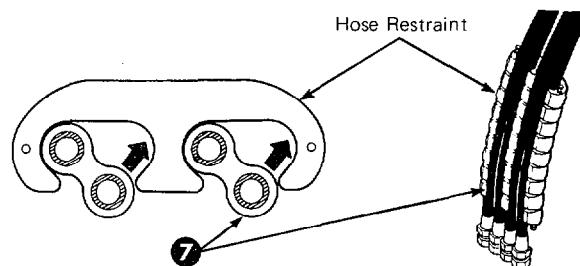
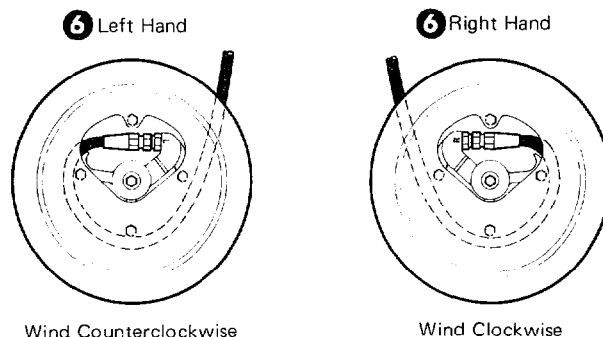
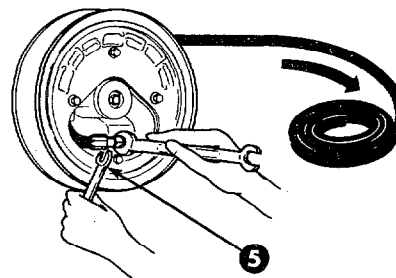

Section 6 Service

6.3 Flange and Hub Removal

- 1 Clamp the reel mounting block in a vice.
- 2 Remove the twinline hoses.
- 3 Remove the four (4) capscrews fastening the flanges and hub to the spring/shaft assembly. For re-assembly, tighten the capscrews to 10–14 ft.-lbs. (13–19 N·m).
- 4 Remove the capscrew, end cap and O-ring from the shaft end. For reassembly, tighten the capscrews to 10–14 ft.-lbs. (13–19N·m).

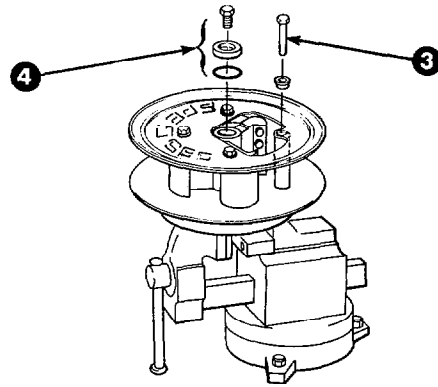

- 5 Grasping both flanges and hub as an assembly, slowly rotate as you lift off the shaft.
- 6 Separate the hub from the flanges.

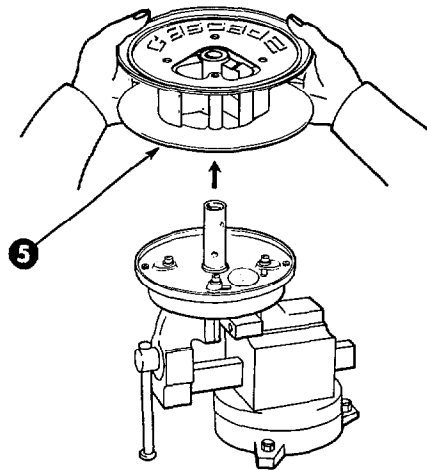

6.4 Spring Assembly Replacement

- 1 Remove the flanges and hub from the shaft as described in Section 6.3.
- 2 Rotate the spring assembly to disengage the spring end from the spring declutching pin. Slide the O-rings and spring assembly off the shaft. Do not damage the shaft O.D.
- 3 Remove four nuts and bolts that retain the spring can cover.
- 4 Place the inner can into the spring can. The spring winding will be exposed for a right hand reel or covered for a left hand reel. Align the spring can notch with the inner can washer.
- 5 Replace the spring can cover. Install the four capscrews and nuts. Tighten to a torque of 30–40 in.-lbs. (3–4 N·m).

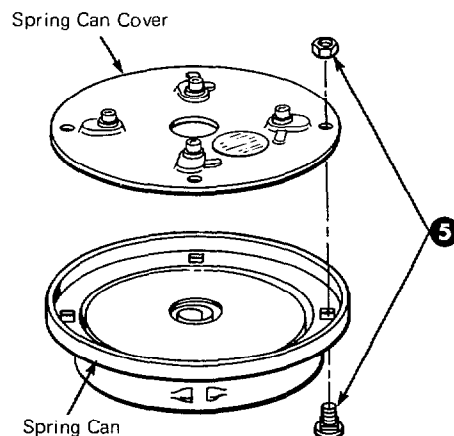
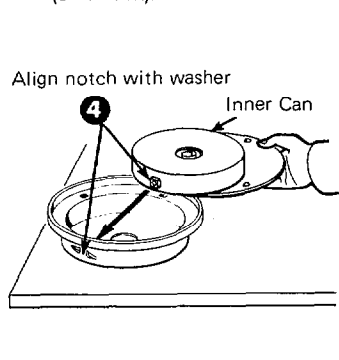
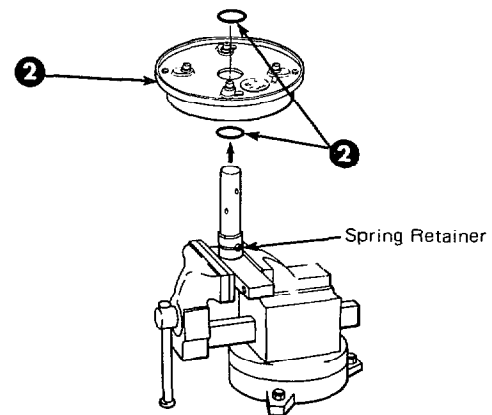

6.5 Hub Seal Replacement

- 1 Remove the flanges and hub as described in Section 6.3.
 - 2 Remove the O-ring and back-up ring seals from the hub bore. Remove the seals by prying them out with the tool in Cascade O-ring Extractor Kit part no. 674424 or a hook type dental tool.
- NOTE:** Do not scratch or damage groove surfaces.
- 3 Rotate the spring assembly to disengage the spring end from the spring declutching pin. Slide the O-ring dust seals and spring assembly off the shaft. Do not damage the shaft O.D.

WARNING: Do not disassemble the spring assembly.

- 4 Remove the capscrews fastening the shaft and mounting block.
- 5 Clean the hub and shaft with a non-corrosive solvent. Inspect the following areas:
 - The sealing surface on the shaft is nickel plated. If minor surface imperfections are noted, use emery cloth (320 Grit) to smooth up. If sharp edges or grooves are found, shaft replacement is necessary.
 - Hub grooves must be free of sharp nicks or projections to prevent cutting of the outside diameter of the O-ring during installation.
 - If the O-ring seal nearest the spring assembly was damaged and allowed hydraulic oil to leak into the spring can, drain the spring can before reassembly. If excessive oil is left in the spring assembly, it will seep out after reassembly and appear as though there is a serious oil leak.

Torque to 10–14 ft.-lbs. (13–19 N·m)

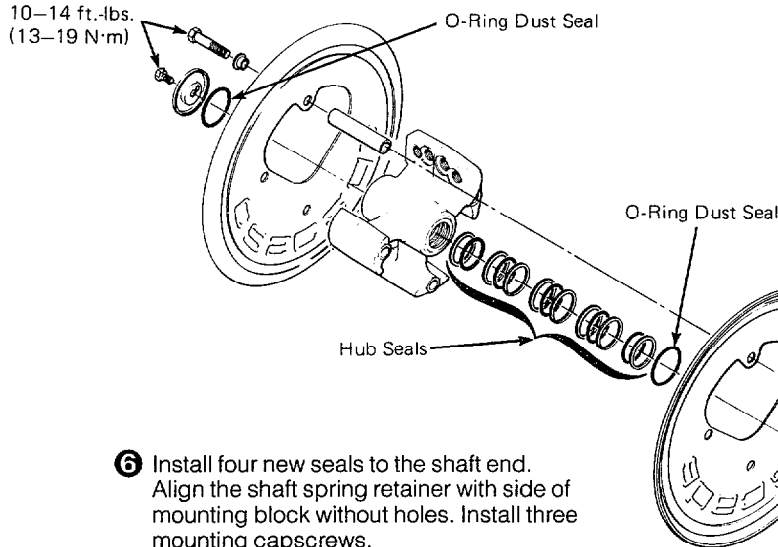

- 6 Install four new seals to the shaft end. Align the shaft spring retainer with side of mounting block without holes. Install three mounting capscrews.
- 7 Apply a liberal amount of petroleum jelly or hydraulic oil (STP) to the shaft, seals and hub before reassembling.
- 8 Install the back-up rings and O-ring seals.
- 9 Reverse steps one (1) through four (4) for reassembly, being careful to rotate the hub slowly as you push it onto the shaft. This will prevent damage to the seals and make reassembly easier. Also be sure O-ring dust seals (3) are in their correct positions.

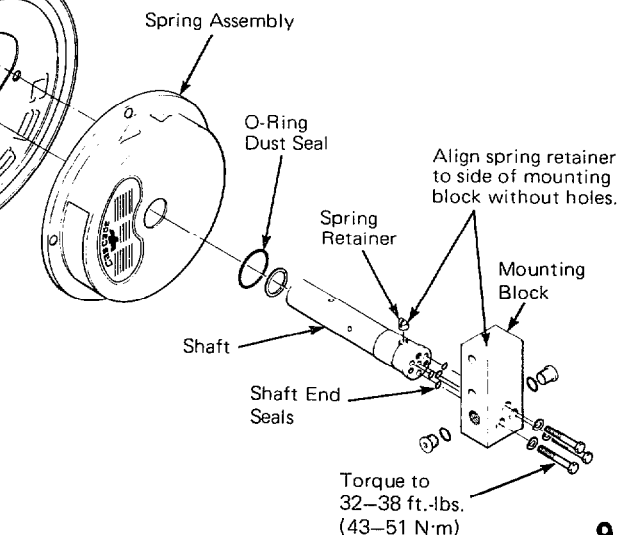
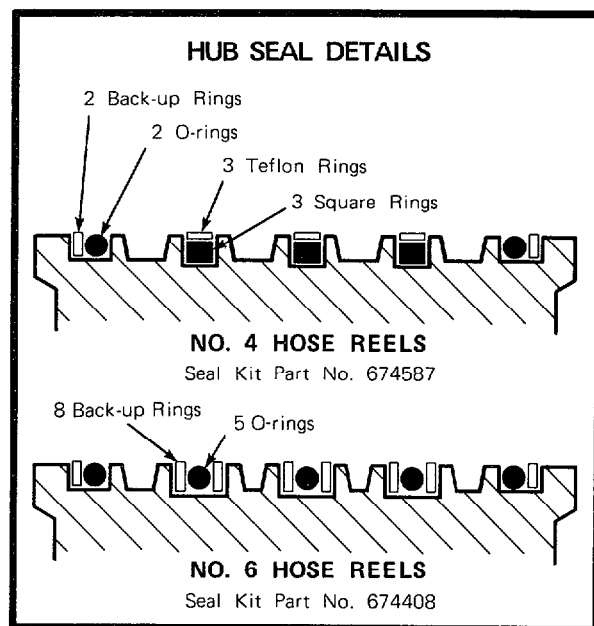
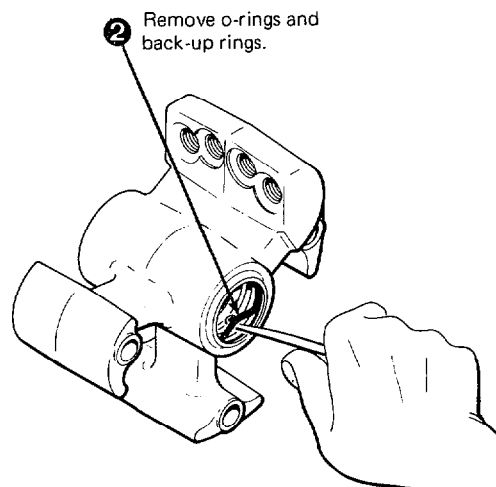

Section 6 Service

6.6 Reversing the Reel Assembly

The reel assembly can be converted from a right hand reel to a left hand reel or from left to right as follows:

- 1 Remove the hose reel flanges and hub as described in Section 6.3.
- 2 Remove four nuts and bolts that retain the spring can cover. For reassembly, tighten the capscrews to a torque of 30–40 in.-lbs. (3–4 N m).



WARNING: Once the spring cover is removed, the spring itself should never be allowed to be turned to any position other than flat without manually covering the spring. The spring is banded but can come out by gravity or bouncing.

- 3 Turn the spring can assembly, making sure that can and cover stay together.

- 4 Lift off the spring can, leaving the cover and inner can on the work bench. Flip over spring can.



WARNING: Do not remove spring from inner can.

- 5 Use the spring cover to slide the inner can into the spring can. Align the spring can notch with the inner can washer. The spring winding will be exposed for a right hand reel and covered for a left hand reel.

- 6 Reverse the spring retainer by removing the spiral snap ring and rotating the retainer 180°. Replace the snap ring.

- 7 For reassembly, reverse the above procedures.

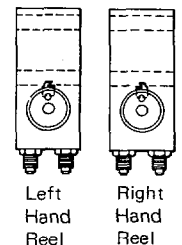
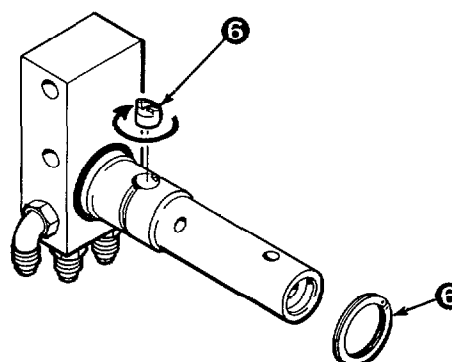
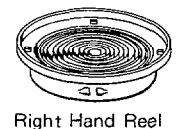
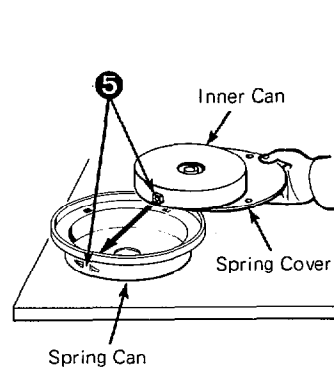
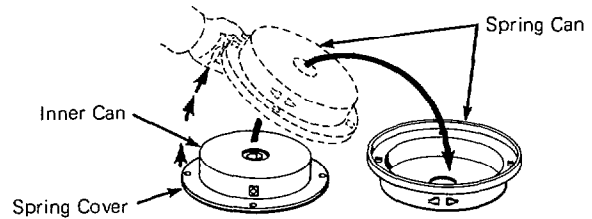
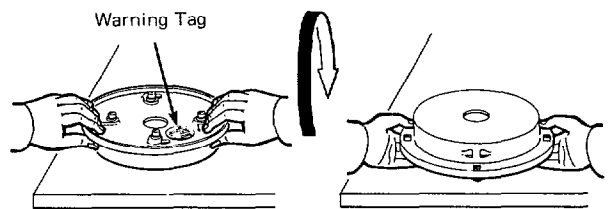
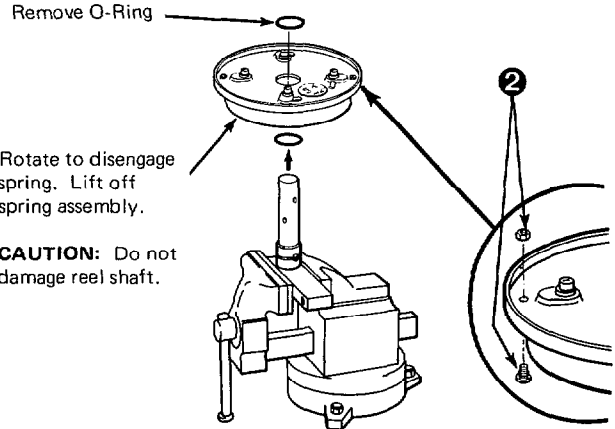

Do you have questions you need answered right now? Call your nearest Cascade Service Department.

AMERICAS

**Cascade Corporation
U.S. Headquarters**
2201 NE 201st
Fairview, OR 97024-9718
Tel: 800-CASCADE (227-2233)
Fax: 888-329-8207

Cascade Canada Inc.
5570 Timberlea Blvd.
Mississauga, Ontario
Canada L4W-4M6
Tel: 905-629-7777
Fax: 905-629-7785

Cascade do Brasil
Rua João Guerra, 134
Macuco, Santos - SP
Brasil 11015-130
Tel: 55-13-2105-8800
Fax: 55-13-2105-8899

EUROPE-AFRICA

**Cascade Italia S.R.L.
European Headquarters**
Via Dell'Artigianato 1
37030 Vago di Lavagno (VR)
Italy
Tel: 39-045-8989111
Fax: 39-045-8989160

Cascade (Africa) Pty. Ltd.
PO Box 625, Isando 1600
60A Steel Road
Sparton, Kempton Park
South Africa
Tel: 27-11-975-9240
Fax: 27-11-394-1147

ASIA-PACIFIC

Cascade Japan Ltd.
2-23, 2-Chome,
Kukuchi Nishimachi
Amagasaki, Hyogo
Japan, 661-0978
Tel: 81-6-6420-9771
Fax: 81-6-6420-9777

Cascade Korea
121B 9L Namdong Ind.
Complex, 691-8 Gojan-Dong
Namdong-Ku
Inchon, Korea
Tel: +82-32-821-2051
Fax: +82-32-821-2055

Cascade-Xiamen
No. 668 Yangguang Rd.
Xinyang Industrial Zone
Haicang, Xiamen City
Fujian Province
P.R. China 361026
Tel: 86-592-651-2500
Fax: 86-592-651-2571

**Cascade India Material
Handling Private Limited**
No 34, Global Trade Centre
1/1 Rambaugh Colony
Lal Bahadur Shastri Road,
Navi Peth, Pune 411 030
(Maharashtra) India
Phone: +91 020 2432 5490
Fax: +91 020 2433 0881

Cascade Australia Pty. Ltd.
1445 Ipswich Road
Rocklea, QLD 4107
Australia
Tel: 1-800-227-223
Fax: +61 7 3373-7333

Cascade New Zealand
15 Ra Ora Drive
East Tamaki, Auckland
New Zealand
Tel: +64-9-273-9136
Fax: +64-9-273-9137

**Sunstream Industries
Pte. Ltd.**
18 Tuas South Street 5
Singapore 637796
Tel: +65-6795-7555
Fax: +65-6863-1368

