

Technical Bulletin

Carriage and Sideshifter Fork Stops

This sheet provides instructions for the inspection and replacement of carriage and sideshifter fork stops. The fork stops are necessary to retain the forks on the carriage. Two new fork stops and decals are included in Service Kit 219400.

It is important that the stops be in place even if a load backrest extension is being used. If the backrest is removed someday, the stops will be required.



WARNING: Do not operate the truck if fork stops at end of top or bottom carriage bar are missing.

- 1 Raise the truck carriage approximately 24 in. (600 mm).
- 2 Inspect the ends of the top and bottom carriage bar. A fork stop must be located on both ends of either the top or bottom carriage bar.
 - If the stops are in place, inspect the welds. Repair if necessary.
 - If one or both stops are missing, they need to be replaced.
- 3 Inspect all welds on the carriage and its general condition. Also inspect the carriage chain anchors.
- 4 The original fork stops were located at the ends of the top or bottom carriage bar. When replacing the stops, it best to install the stops in their original location. **Mast carriages usually have the stops on the top carriage bar to avoid interference with a sideshifter. For sideshift carriages the stops can be located on either the top or bottom carriage bar.**
 - If a sideshifter is mounted on the mast carriage, check for interference when the sideshifter is positioned fully left or right.
 - If an attachment is mounted on the mast carriage, check for interference with the upper mounting hooks.
- 5 To replace the fork stop(s), first clean the carriage and grind away any left over weld from where the previous stops were located.

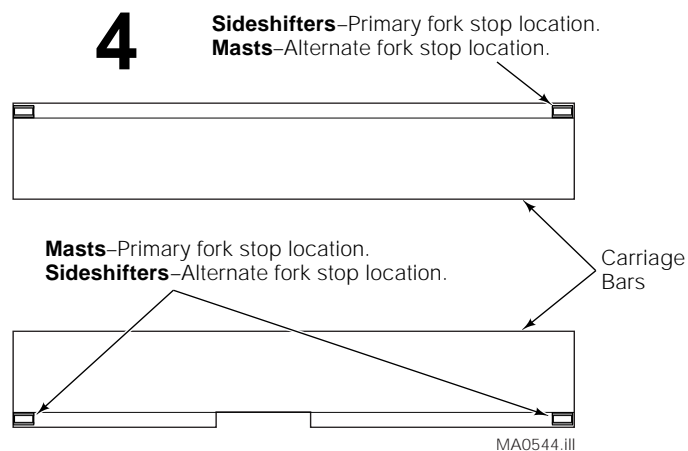
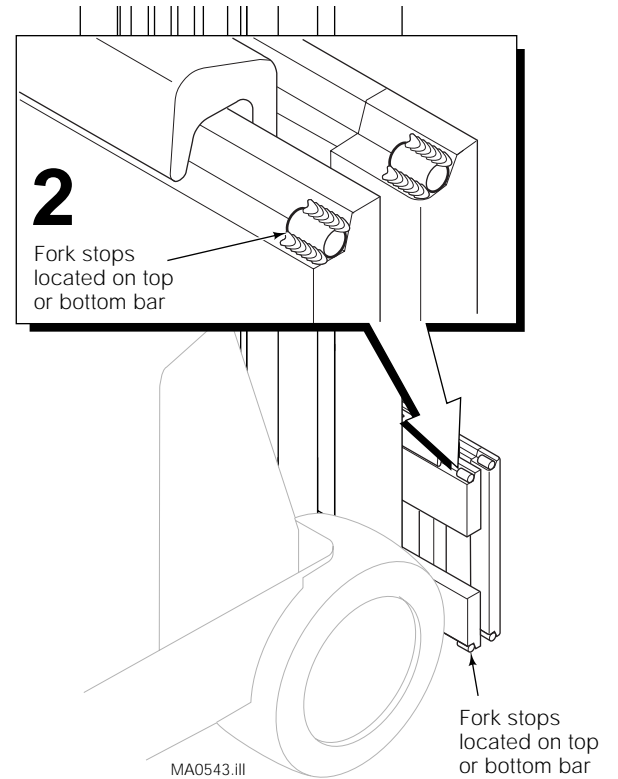

Part No. 219401

NOTE: This information should not be interpreted as the basis for warranty claims unless so designated.

cascade®

For Technical Support . . .

Call: 1-800-227-2233

OR

Write: Cascade Corporation, P.O. Box 20187, Portland, OR 97220

To Order Parts . . .

Call: 1-888-227-2233

OR

Write: Cascade Corporation, 2501 Sheridan Ave., Springfield, OH 45505

- 6** Position the fork stops at the ends of the appropriate carriage bar.

NOTE: Fork stops can be fabricated from 1/2 in. (13 mm) diameter by 1/2 in. (13 mm) in. long mild steel bar stock.

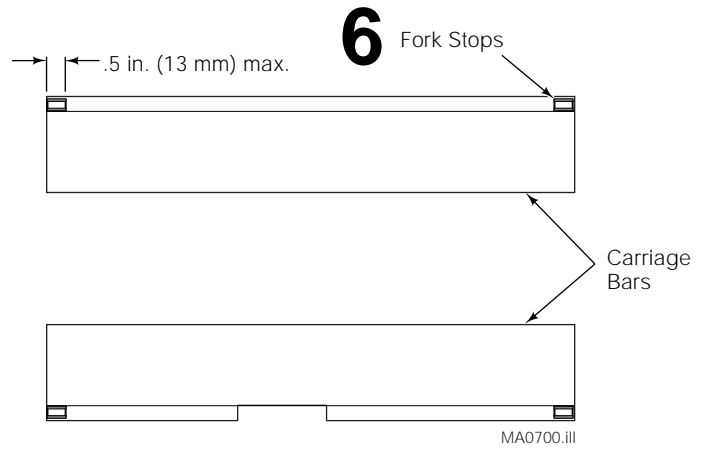

- 7** Apply welds to the fork stops using one of the following methods:

WELD METHOD A – Attach the ground wire to the upright. Weld using FCAW (Flux Core Arc Weld) AWS E70T-1 1/16 in. (1.5 mm) diameter wire with 100% CO² shielding gas. Apply a 5/32 in. (4 mm) fillet holding a close arc. Do not oscillate or use a wash bead pattern. Let the welds slow cool.

WELD METHOD B – Attach the ground wire to the upright. Weld using E-7018 low hydrogen 1/8 in. (3 mm) electrodes. Use reverse polarity or a AC welding machine set at 115-145 amps. **Do not use electrodes exposed to moisture without first re-drying them at 200° F (75° C) for 2 hours.** Apply a 5/32 in. (4 mm) groove weld holding a close arc. Do not oscillate or use a wash bead pattern. Let the welds slow cool.

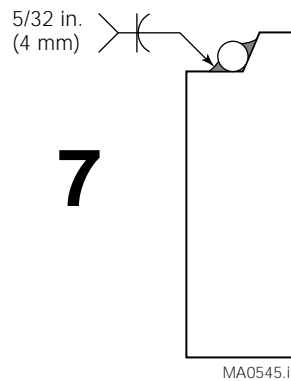

- 8** Remove slag and inspect the welds. The following defects are not allowed: undercut, overlap, stress cracks and porosity.

- 9** Clean the weld area and repaint.

Installing Forks

Forks are installed on the carriage using the fork loading slot in the lower carriage bar. Position the fork on a pallet or 4x4 in. blocks. Drive forward aligning the fork lower hook with the carriage fork loading slot. Tilt the mast forward to engage the fork upper hook. Raise the carriage and tilt back for the lower hook to enter through the slot. Raise the fork detent pin and push the fork to either side.

