



*Designed with  
great visibility,  
and superior  
durability.*

## Handle Barrel Style Kegs Efficiently and Safely

### APPLICATIONS

Designed for the beverage industry, the Cascade Keg Handler allows you to safely handle multiple kegs in one load. This attachment is suitable for use while loading and unloading trailers at breweries, distributors and warehouse operations.

### FEATURES

- Three adjustable scalloped forks
- Keg stabilizer arms for maximum load stability
- Integral load backrest
- Class 2 or 3 bolt-on lower hooks
- Increased visibility over and through the frame

### OPTIONS

- Available in both Class 2 and Class 3 mounting groups

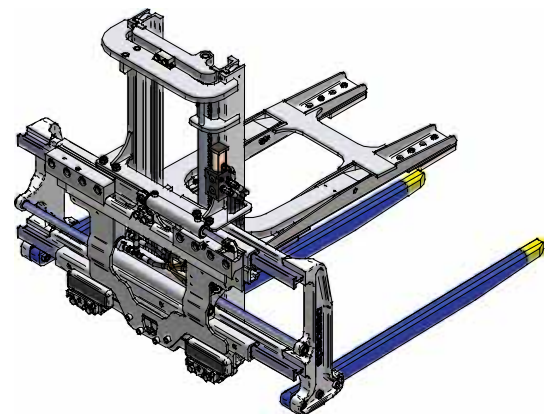

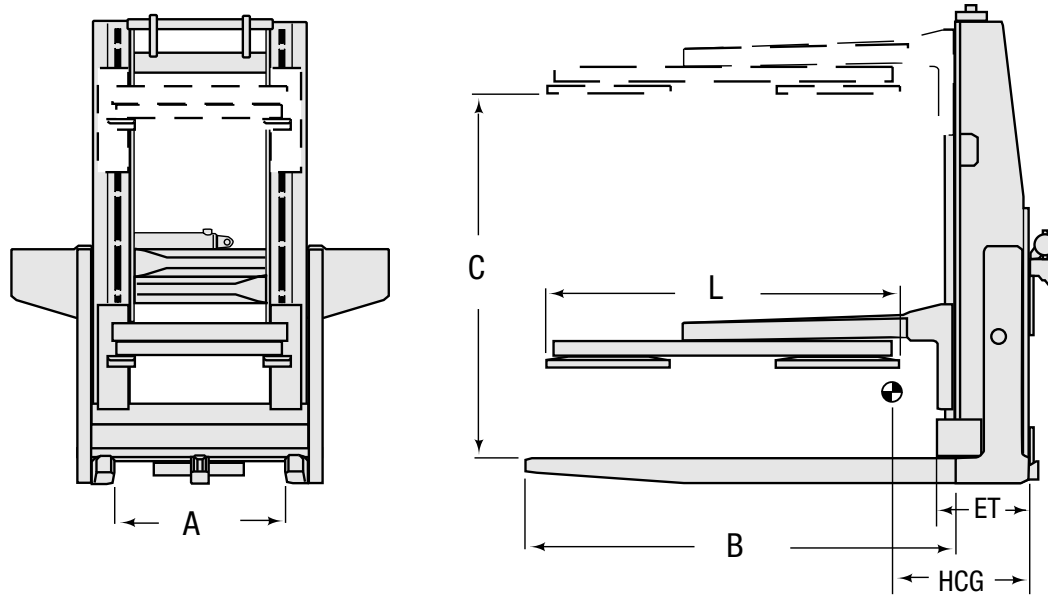

Catalogue Order No.	Capacity @ Load Centre kg@mm	Fork Length (mm) B	Opening Fork Range (mm) A	Stabilizer range (mm) C	Effective Thickness (mm) ET	Horizontal Centre of Gravity (mm) HCG	Weight kg	Mounting Class ISO 2328
35D-BKS-B156	1680@625	1170	485-1310	250-1959	305	210	570	3A

## HYDRAULIC FUNCTIONS

Hydraulic Functions	Truck Auxillary Valves Required
2	2

## MOUNTING CLASS INFORMATION

Mounting Class	Truck Capacity @ Load Centre
3	2501-4999 kg @ 500 mm

## HYDRAULIC FLOW & PRESSURE (L/MIN.)

Minimum Flow	Recommended Flow	Maximum Flow	Maximum Pressure bar
	Consult Cascade		160